



JA71-Pxx / Txx Switch Mounting Panels

Data Sheet



Description

The JA71-Pxx and JA71-Txx series of mounting panels allow the aircraft customizer to install a professionally finished panel for the ever-present extra switches.

The -Txx series of panels can accommodate 3, 4 or 5 standard aircraft grade toggle switches. (e.g. Honeywell TL Series or MS24523)

The -Pxx series of panels can accommodate 3, 4 or 5 square pushbutton switches (e.g. Korry Chromalux 389, Aerospace Optics Vivisun type I or III, Staco Systems Series 90)

All of these panels are manufactured as engraving-ready and can be laser engraved to suit the customer's requirements.

Jupiter includes two Switch Hole Covers in every order for your customizing needs.



Specifications

Installation

- JA71-P33 Pushbutton, 3 switches, 3 Dzus high
- JA71-P43 Pushbutton, 4 switches, 3 Dzus high
- JA71-P53 Pushbutton, 5 switches, 3 Dzus high

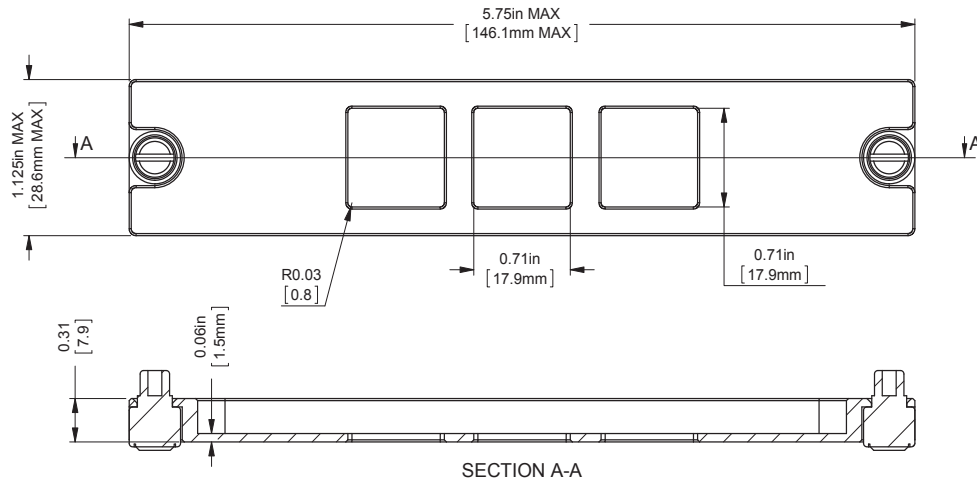

WEIGHT: 0.11 lbs [0.05 kg] MAX.

- JA71-T35 Toggle Switch, 3 switches, 5 Dzus high
- JA71-T45 Toggle Switch, 4 switches, 5 Dzus high
- JA71-T55 Toggle Switch, 5 switches, 5 Dzus high

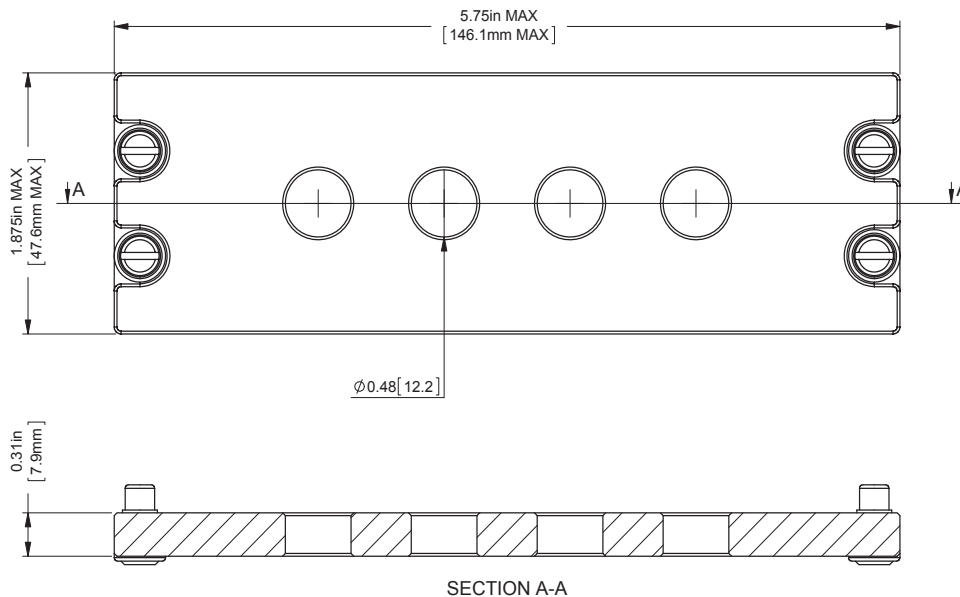

WEIGHT: 0.35 lbs [0.16 kg] MAX.