



JUPITER AVIONICS
CORPORATION

JA23-001

Speaker Amplifier



Installation and Operating Manual

Rev A

Jupiter Avionics Corporation
1959 Kirschner Road
Kelowna BC
Canada V1Y 4N7
Tel: +1 778 478 2232
Toll-Free: 1 855 478 2232
www.jupiteravionics.com



Table of Contents

SECTION 1 - DESCRIPTION	1
1.1 System Overview	1
1.2 Features Overview	1
1.3 Inputs and Outputs	1
1.3.1 Inputs	1
1.3.2 Outputs	1
1.4 Specifications	2
1.4.1 Electrical Specifications	2
1.4.2 Mechanical Specifications	3
1.4.3 Environmental Specifications	3
SECTION 2 – INSTALLATION	4
2.1 Introduction	4
2.2 Continued Airworthiness	4
2.3 Unpacking and Inspecting Equipment	4
2.3.1 Warranty	4
2.4 Installation Procedures	4
2.4.1 Installation Limitations	4
2.4.2 Cabling and Wiring	4
2.4.3 Mechanical Installation	5
2.4.4 Post Installation Checks	5
2.5 Speaker Operation	5
2.6 Installation Kit	6
2.6.1 Recommended Crimp Tools	6
2.7 Installation Drawings	6
SECTION 3 – OPERATION	7
3.1 Introduction	7
3.2 Controls	7
3.2.1 Speaker Push To Talk	7
3.2.2 Optional Speaker Mute Switch	7
3.2.3 Optional Volume Level Potentiometer	7
Appendix A - Installation Drawings	A1
A1 Introduction	A1
A2 Installation Drawings	A1
Appendix B - Installation Documents	B1
B1 Airworthiness Approval	B2
B2 Instructions for Continued Airworthiness	B2



JA23-001 Speaker Amplifier

SECTION 1 - DESCRIPTION

1.1 System Overview

The JA23-001 speaker Amplifier is an integrated speaker amplifier which allows the user to monitor receive audio without a headset.

1.2 Features Overview

The JA23-001 provides a single speaker with up to 10 Watts output.

The JA23-001 supports speaker impedances of 3.2, 4, 8 and 16 Ohm and greater.

The JA23-001 supports three Differential audio inputs.

The JA23-001 supports one single ended microphone input with Mic bias.

The JA23-001 supports a speaker mute and Push-to-talk input.

The JA23-001 supports an external speaker level control.

1.3 Inputs and Outputs

Refer to the JA23-001 [connector maps](#) for the mating connector designators and pin assignments for the input and output signals.

1.3.1 Inputs

Name	Qty	Type
SPEAKER MIC HI/LO	1	Audio signal
POWER INPUT	1	Power supply, 28 Vdc
SPEAKER PTT	1	Control signal active low
SPEAKER INPUT 1 to 3 HI/LO	3	Audio signal
SPEAKER LEVEL & MUTE HI/LO	1	Analog control signal

1.3.2 Outputs

Name	Qty	Type
SPEAKER OUTPUT HI/LO	1	Audio signal

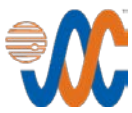

1.4 Specifications

1.4.1 Electrical Specifications

Power Input

Primary nominal voltage	28 Vdc
Maximum voltage	32.2 Vdc
Minimum voltage	22.0 Vdc
Emergency voltage	18.0 Vdc
POWER INPUT 'off' voltage	≤ 15.0 Vdc
Input current at Emergency voltage	≤ 1.0 A

1.4.1.1 Audio Performance

Rated Input Level

SPEAKER INPUT audio rated input level	1.00 Vrms ±10%
SPEAKER MIC input level	250 mVrms ±10%

Rated Output Level

SPEAKER OUTPUT rated output level	6.3 Vrms ±10%
-----------------------------------	---------------

Audio Frequency Response

Audio output audio frequency response	≤ 3dB from 300 to 6000 Hz
---------------------------------------	---------------------------

Distortion Characteristics

Audio output distortion at rated power	≤ 10%
Audio output distortion at 10% of rated power	≤ 3%

Input Impedance

SPEAKER MIC input Impedance	150 Ω ±10%
SPEAKER INPUT Impedance	1000 Ω ±10%

Output Load

SPEAKER load impedance	≥ 3.2 Ω
------------------------	---------

Input to Output Crosstalk and Bleed-through Level

Input to Output crosstalk	≤ 55 dB
---------------------------	---------

Input to Input Crosstalk Level

Input to Input crosstalk	≤ 60 dB
--------------------------	---------

Audio Noise Level without Signal

Noise level below the rated output	≥ 60 dB
------------------------------------	---------

1.4.1.2 Audio Performance, Other

SPEAKER MIC inputs designed for MIC type	amplified dynamic/electret
Microphone input bias voltage	12 Vdc ± 10%
Microphone input circuitry type	single ended
SPEAKER INPUT audio input circuitry type	differential



1.4.1.3 Discrete Signals

Active low control input, active signal level Active $\leq +3$ Vdc
 low control input, active signal level sources Active 0.1 to 10 mA
 low control input signals have internal pull-up resistor

1.4.1.4 Speaker Level and Mute

Level and Mute Control	SPEAKER OUTPUT
Resistor between pins 6 and 14 ≥ 1 k Ω ,	0 dB = rated output
Resistor between pins 6 and 14 ≤ 10 Ω	-32 \pm 3 dB of rated output
Pin 6 is shorted to power ground	≤ -60 dB of rated output

1.4.2 Mechanical Specifications

Height 1.38 in [35.1 mm] max
 Depth not including connectors 6.30 in [160.0 mm] max
 Width 2.60 in [66.0 mm] max
 Weight 0.68 lbs [0.31 kg] max
 Material brushed aluminum with clear conversion coating
 Connector (Speaker) J1 One 15-pin D-Sub male V5 locking
 Mounting 4 x 10-32 fasteners
 Bonding ≤ 2.5 m Ω
 Installation kit part number INST-JA23

1.4.3 Environmental Specifications

The JA23-001 Speaker Amplifier has been tested to the environmental conditions listed below.

Temperature:
 Operating -45 to +70°C
 Ground Survival -55 to +85°C
 Altitude 50,000 ft
 Shock, Crash Safety 6 g, 20 g for 11 ms

JA23-001 Speaker Amplifier

SECTION 2 – INSTALLATION

2.1 Introduction

This section contains unpacking and inspection procedures, installation information, and post-installation checks.

2.2 Continued Airworthiness

Maintenance of the JA23-001 is on condition only. Scheduled inspection and/or periodic maintenance of this unit is not required.

2.3 Unpacking and Inspecting Equipment

Unpack the equipment carefully. Check for shipping damage and report any problems to the relevant carrier. Confirm that the Authorized Release Certificate or Certificate of Conformance is included. Complete the on-line warranty card from the Jupiter Avionics Corporation (JAC) website - www.jupiteravionics.com/warrantyregistration

2.3.1 Warranty

This product manufactured by JAC is warranted to be free of defects in workmanship or performance for 2 years from the date of installation by an approved JAC dealer or agency. This warranty covers the cost of all materials and labour to repair or replace the unit, but does not include the cost of transporting the defective unit to and from JAC or its designated warranty repair centre, or of removing and replacing the defective unit in the aircraft. This warranty does not cover failures due to abuse, misuse, accident, or unauthorized alteration or repairs.

THIS WARRANTY IS VOID IF THE PRODUCT IS NOT INSTALLED BY AN AUTHORIZED JAC DEALER. If the on-line warranty card is not completed, the product will be warranted from the date of manufacture.

Contact JAC for return authorization, and for any questions regarding this warranty and how it applies to your unit(s). JAC is the final arbiter concerning warranty issues.

2.4 Installation Procedures



WARNING: Loud noise can cause hearing damage. Set the headset volume to minimum before conducting tests, and slowly increase the volume to a comfortable listening level.



CAUTION: The power input circuitry of the unit may be damaged if the installation does not conform to the wiring instructions in this manual.

2.4.1 Installation Limitations

Those installing the JA23, on or in a specific type or class of aircraft, must determine that the aircraft installation conditions meet standards. The JA23 may be installed only by following the applicable airworthiness requirements.

2.4.2 Cabling and Wiring

All wire shall be selected in accordance with the original aircraft manufacturer's maintenance instructions, or AC43.13-1B Change 1, Paragraphs 11-76 through 11-78. Unshielded wire types shall qualify to MIL-W-22759 as specified in AC43.13-1B Change 1, Paragraphs 11-85, 11-86, and listed in Table 11-11. For shielded wire applications, use Tefzel MIL-C-27500 shielded wire with tag ring or equivalent (for shield terminations) to make the most compact and easily terminated interconnect. Follow the Connector Map in Appendix A of this manual.



Allow 3" from the end of the shielded wiring to the shield termination to allow the connector hood to be easily installed. Refer to the Interconnect drawing in Appendix A of this manual for shield termination details. Note that this unit has a 'clamshell' hood that is installed after the wiring is complete.

Maintain wire segregation and route wiring in accordance with the original aircraft manufacturer's maintenance instructions.

Unless otherwise noted, all wiring shall be a minimum of 24 AWG, except power and ground lines, which shall be a minimum of 22 AWG. Refer to the Interconnect drawing for additional specifications. Check that the ground connection is clean and well secured, and that it shares no path with any electrically noisy aircraft accessories such as blowers, turn-and-bank instruments, or similar loads.

2.4.3 Mechanical Installation

The JA23-001 can be mounted in any attitude and location with sufficient clearance for the connector and wiring harness. It requires no direct cooling.

2.4.4 Post Installation Checks

2.4.4.1 Voltage/Resistance checks.

Do not attach this unit until the following conditions are met:

- a) Check P1 pin **1** for +28 Vdc relative to ground.
- b) Check P1 pin **9** for continuity to ground (less than 0.5 Ω).
- c) Check P1 pins **6** and **14** for continuity to ground (less than 0.5 Ω) when relevant switch is closed (if connected).
- d) Check all pins for shorts to ground or adjacent pins.

2.4.4.2 Configuration

There are no configurable settings on the JA23-001.

2.4.4.3 Power on Checks.

Power up the aircraft's systems and confirm normal operation of all functions of the JA23. Refer to section 2.5 and [section 3.2](#) for all operating functions.

When all performance checks are satisfied, complete the necessary regulatory documentation before releasing the aircraft for service. Refer to [Appendix B](#).

2.5 Equipment Function

When the SPEAKER PTT input is active, the sum of the SPEAKER INPUTS and SPEAKER MIC is routed to the SPEAKER OUTPUT.

When the SPEAKER LEVEL AND MUTE HI input is grounded, the SPEAKER OUTPUT is muted.

When the SPEAKER LEVEL AND MUTE HI input is connected to the SPEAKER LEVEL AND MUTE LO via an external control, the SPEAKER OUTPUT level is adjusted by the external speaker level control.



2.6 Installation Kit

The kit required to install this unit is not included with the unit.

The installation kit (Part # INST-JA23) consists of the following:

Quantity	Description	JAC Part #
1	TAG ring 3/8 in I/D	CON-5500-0375
1	D-Sub 15-pin crimp socket connector assembly	CON-3420-0015
1	3/4" Inside Diameter - Black, Heat Shrink Tube	WIR-HTSK-0750
1	1 k Ohm Panel pot	POT-1RV6-1K00
1	VOL Knob	KNB-1100-VOL
1	Label	LAB-PLAS-0154

2.6.1 Recommended Crimp Tools

Standard D-Sub Crimp Tool Chart			
Tool Type	Hand crimping tool	Positioner	Insertion/extractor tool
POSITRONIC	9507-0-0-0	9502-5-0-0	4711-2-0-0
DANIELS	AFM 8	K13-1	91067-2
MIL-SPEC	M22520/2-01	M22520/2-08	M81969/1-02

2.7 Installation Drawings

The drawings and documents required for Installation can be found in [Appendix A](#) of this manual.



JA23-001 Speaker Amplifier

SECTION 3 – OPERATION

3.1 Introduction

This section contains the operating instructions for the JA23-001.

3.2 Controls



Note: The JA23-001 has no integral operator controls. Confirm details of the speaker system with your installing agency.

3.2.1 Speaker Push To Talk

The JA23-001 can be provided with an external Speaker PTT switch that will allow speaker operation when grounded.

3.2.2 Optional Speaker Mute Switch

The JA23-001 can be provided with an external Speaker Mute Switch that will mute the speaker when grounded.

3.2.3 Optional Volume Level Potentiometer

The JA23-001 can be provided with an external pot that can be used to control the speaker volume level.



Installation and Operating Manual

Appendix A - Installation Drawings

A1 Introduction

The drawings necessary for installation and troubleshooting of the JA23-001 Speaker Amplifier are in this Appendix, as listed below.

A2 Installation Drawings

DOCUMENT	Rev
JA23-001 Connector Map	A
JA23-001 Interconnect	A
JA23-001 Mechanical Installation	A

SPEAKER CONNECTOR

P1
 15 PIN FEMALE DMIN
 MATING CONNECTOR

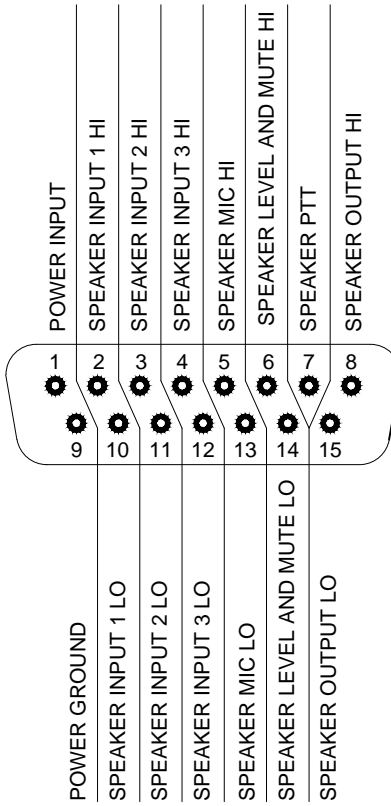



VIEW IS FROM REAR OF MATING CONNECTOR

PREPARED	TAT	JUPITER AVIONICS CORPORATION			
CHECKED					TITLE
APPROVED		Speaker Amplifier P1 Connector Map			
CONFIDENTIAL & PROPRIETARY TO JUPITER AVIONICS CORP.		NCAGE CODE L00N3	PART NO. JA23-001		
		DOC NO. JA23-001 Connector Map Rev A.dwg			

JA23-001 INTERCONNECT WIRING NOTES



NOTES

1. ALL WIRE SIZE SHOULD BE 24 AWG MIN UNLESS OTHERWISE SPECIFIED. UNSHIELDED WIRE SHOULD BE SELECTED PER FAA AC43.13-1B CHANGE 1 PARA 11-76 TO 11-78. WIRE TYPES SHOULD BE IN ACCORDANCE WITH MIL-W-22759 AS DESCRIBED IN FAA AC43.13-1B CHANGE 1 PARA 11-85 AND 11-86 AND LISTED IN TABLE 11-11 OR 11-12. ALL SHIELDED CABLE SHOULD BE IN ACCORDANCE WITH MIL-DTL-27500 (REVISION H OR LATER).
2. CONNECTION TO AIRFRAME GROUND SHOULD BE MADE WITH 20 AWG WIRE. LENGTH NOT TO EXCEED 3 FT (0.91 M).
3. CABLE SHIELDS AT THE JA23 CONNECTOR END SHOULD BE TERMINATED TO AIRFRAME GROUND USING THE TAG RING SUPPLIED IN THE INSTALLATION KIT OR EQUIVALENT.
4. SPEAKER PTT MUST BE GROUNDED TO ALLOW SPEAKER OPERATION.
5. SPEAKER LEVEL CAN BE ADJUSTED BY PLACING A RESISTOR BETWEEN PINS 6 & 14.
 OPEN CIRCUIT OR 1K Ohm = FULL RATED OUTPUT POWER
 <10 Ohm = -32 dB FROM RATED OUTPUT POWER

PREPARED	TAT/CPM			
CHECKED				
APPROVED		Speaker Amplifier Interconnect Notes		SHEET 1/3
CONFIDENTIAL & PROPRIETARY TO JUPITER AVIONICS CORP.		NCAGE CODE L00N3	PART NO. JA23-001	
		DOC NO. JA23-001 Interconnect Rev B.dwg		

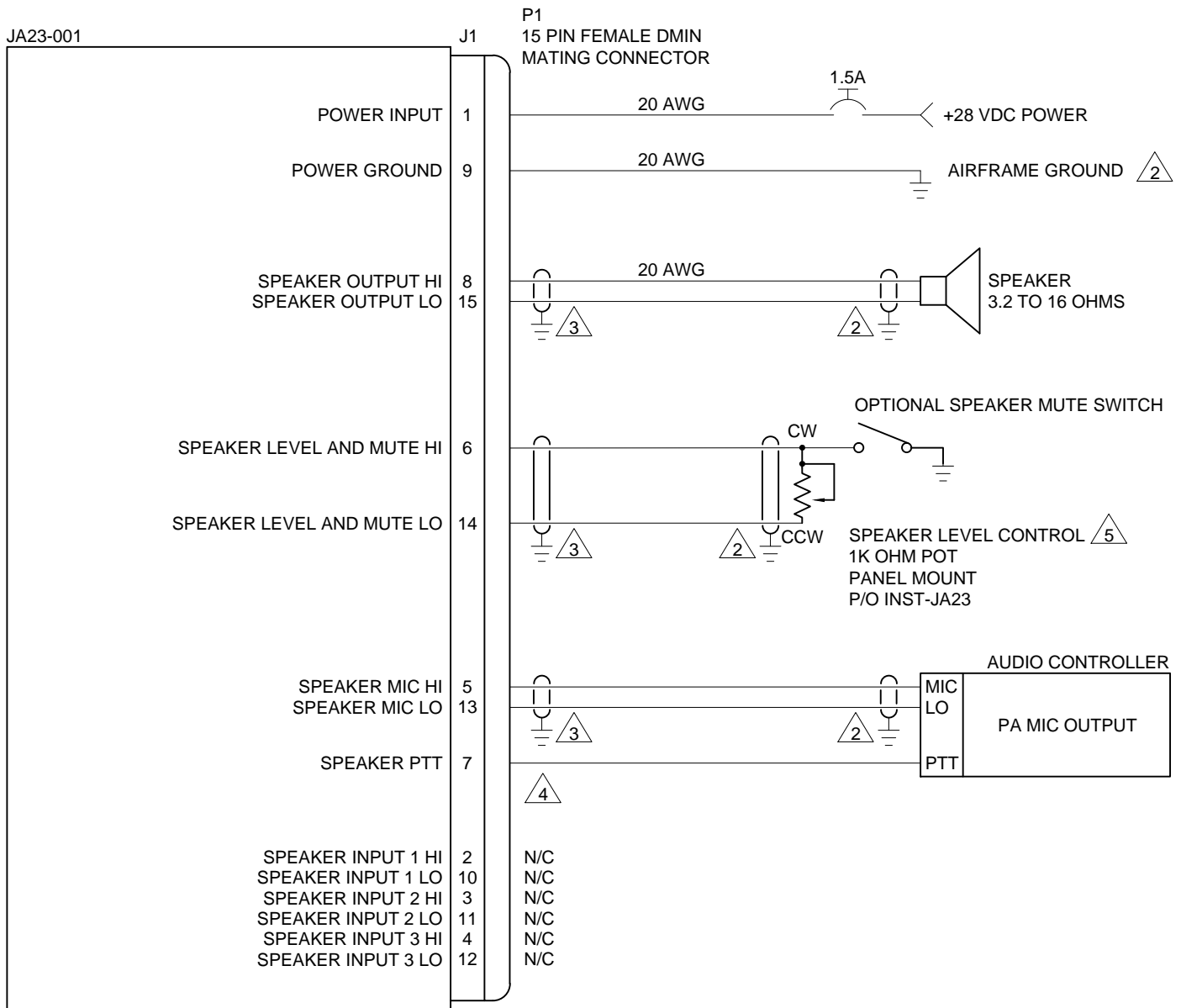
JA23-001



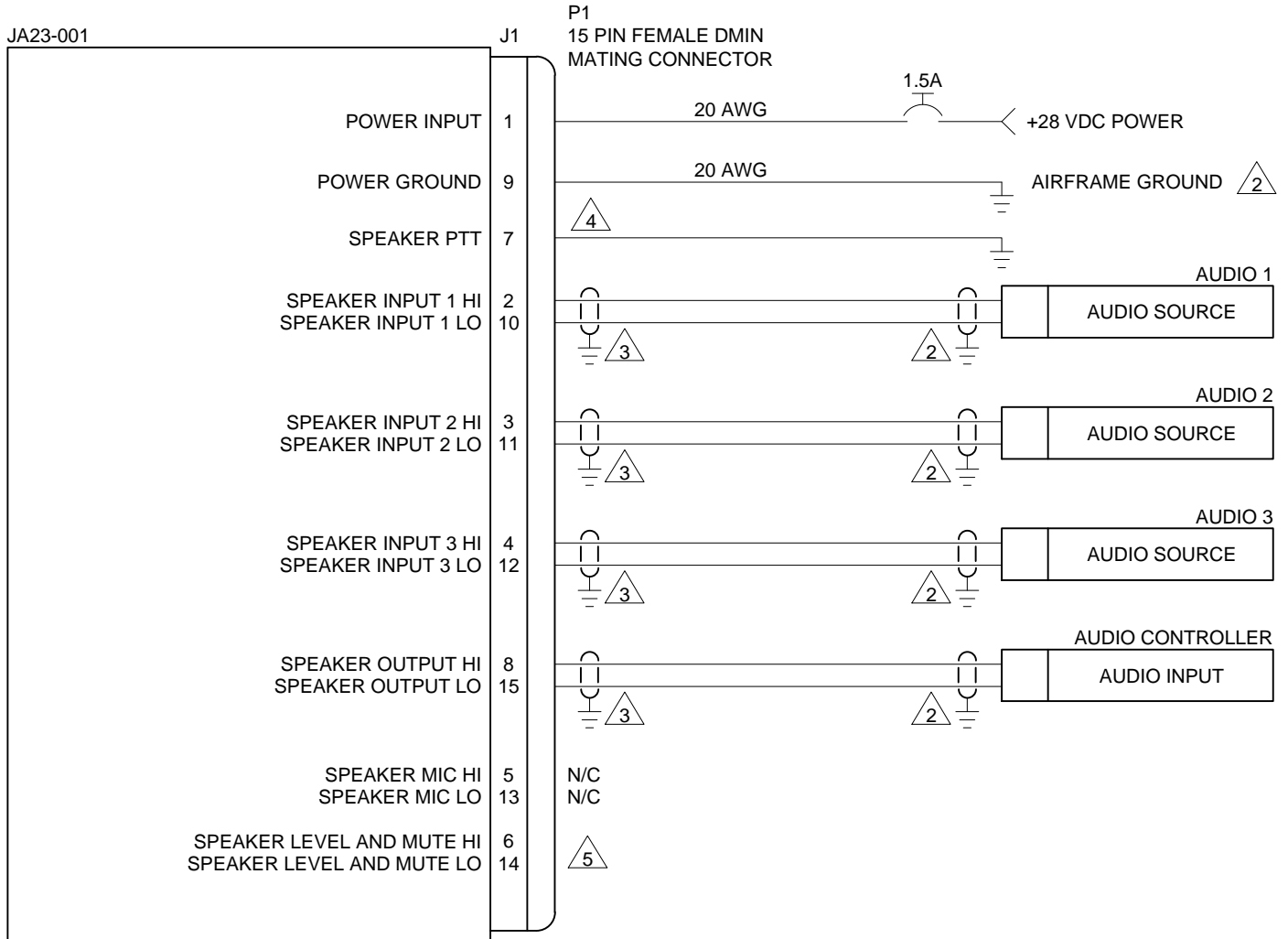

PREPARED	TAT/CPM			
CHECKED				
APPROVED		Speaker Amplifier J1 Interconnect		SHEET
CONFIDENTIAL & PROPRIETARY TO JUPITER AVIONICS CORP.		NCAGE CODE L00N3	PART NO. JA23-001	2/3
		DOC NO. JA23-001 Interconnect Rev B.dwg		

OPTIONAL CONFIGURATION AUDIO SUMMING AMPLIFIER

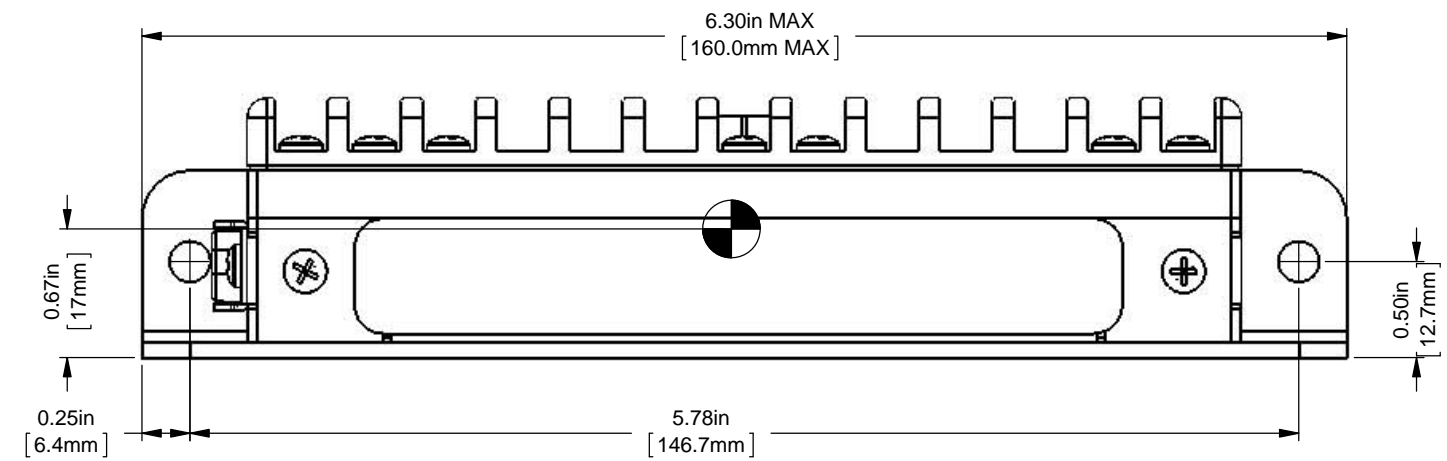
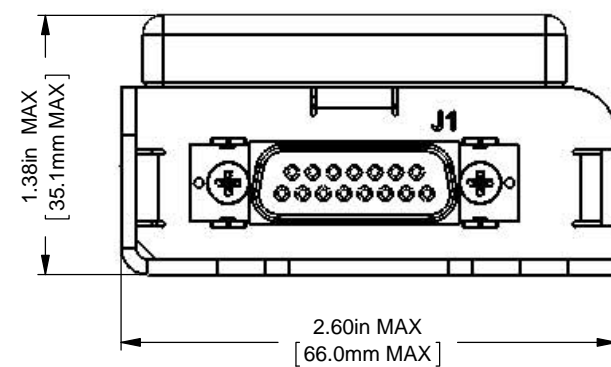
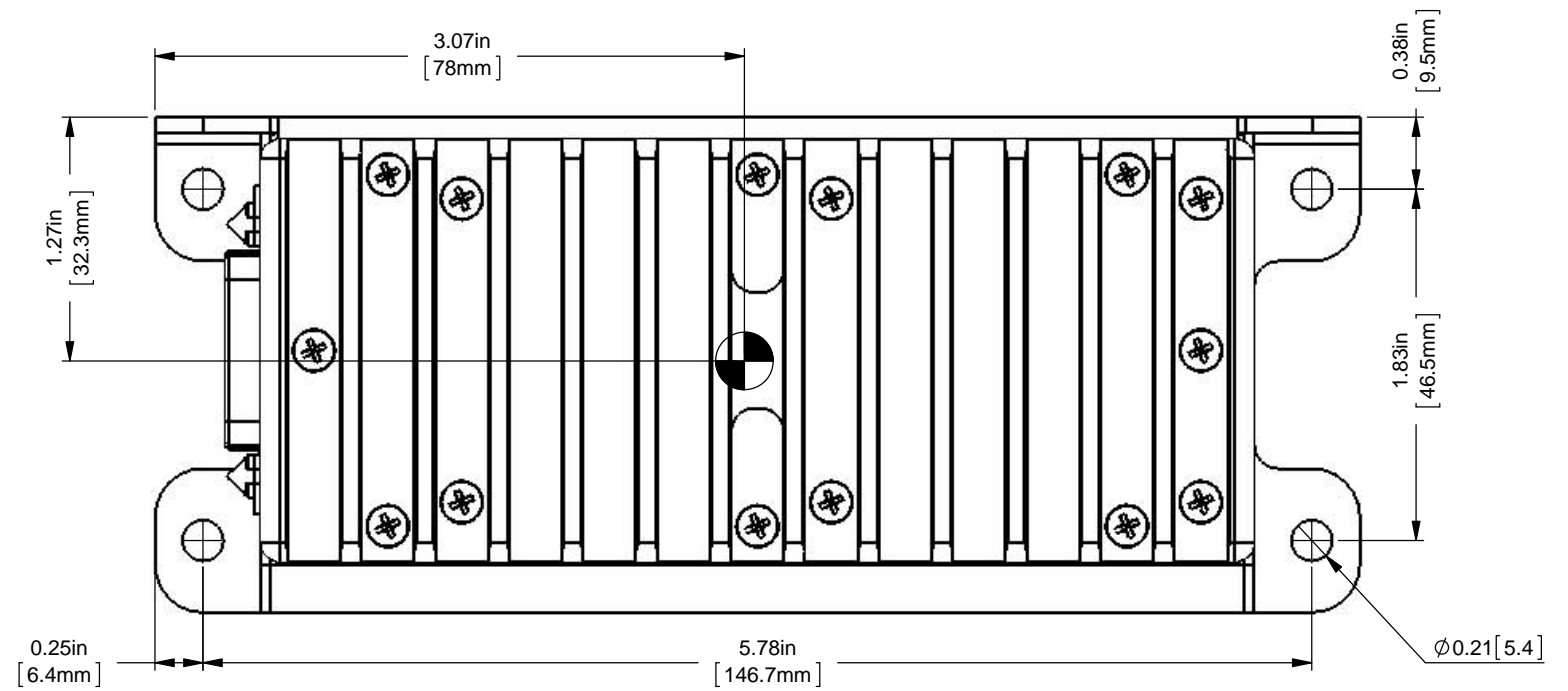
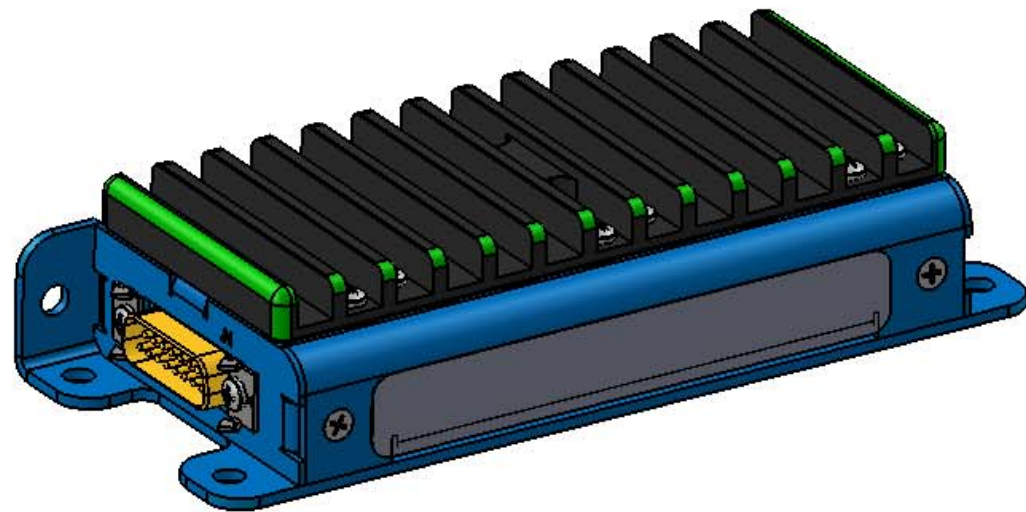

PREPARED	TAT/CPM	JUPITER AVIONICS CORPORATION		
CHECKED		TITLE Speaker Amplifier Optional Audio Summing Amplifier		
APPROVED		NCAGE CODE L00N3	PART NO. JA23-001	SHEET 3/3
CONFIDENTIAL & PROPRIETARY TO JUPITER AVIONICS CORP.		DOC NO. JA23-001 Interconnect Rev B.dwg		



 CENTER OF GRAVITY
 $\pm 0.03\text{in}$ [0.8mm]

WEIGHT: 0.68 lbs [0.31 kg] MAX.

UNLESS OTHERWISE SPECIFIED
 DIMENSIONS ARE IN INCHES
 ANGLES ARE IN DEGREES
 TOLERANCES:
 1 DEC PLACE: ± 0.1
 2 DEC PLACE: ± 0.01
 3 DEC PLACE: ± 0.005
 ANGLES: ± 0.5 DEG

PREPARED	TAT
CHECKED	JAC 10-23-17 CPM
APPROVED	JAC 10-24-17 KDV

 JUPITER AVIONICS CORPORATION		TITLE	
		Speaker Amplifier	
NCAGE CODE	PART NO.	SHEET	
L00N3	JA23-001	1/1	
MATERIAL: N/A		DOC. NO.	
FINISH: N/A		JA23-001 Mechanical Installation Rev A.SLDDRW	



Installation and Operating Manual

Appendix B - Installation Documents



B1 **Airworthiness Approval**

Airworthiness approval of the JA23-001 Speaker Amplifier may require completion of a TCCA Major Modification Report per CAR STD (AWM) 571 Appendix L, or a FAA Form 337. The sample wording for a description of the work is provided to assist the Installing Agency in preparing Instructions for Continued Airworthiness (ICA) when replacing an existing speaker amplifier with a Jupiter Avionics JA23-001 Speaker Amplifier. This sample may be modified appropriately for new installations. It is the installer's responsibility to determine the applicability of the method used. Installations performed outside Canada must follow the applicable aviation authority's regulations.

Sample Wording:

Removed the existing [model] speaker amplifier and replaced with a Jupiter Avionics JA23-001 Speaker Amplifier in [aircraft location].

Installed in accordance with the JA23-001 Installation Manual, Revision [], and AC 43.13-2, Chapters 2, and 3.

The JA23-001 interfaces with existing aircraft systems per the Installation Manual instructions.

The JA23-001 Installation Manual provides detailed installation instructions and wiring diagrams (Section 2, and Appendices A and B).

Power is supplied to the JA23-001 through an existing []-Amp circuit breaker that was previously used by the original speaker amplifier. The net electrical load is unchanged.

Aircraft equipment list, weights and balance amended. Compass compensation checked and found to conform to applicable regulations.

B2 **Instructions for Continued Airworthiness**

Maintenance of the JA23-001 Speaker Amplifier is "on condition" only. Refer to the JA23-001 Maintenance Manual. Periodic maintenance of the JA23-001 is not required.

The following sample Instructions for Continued Airworthiness (ICA) provides assistance in preparing ICA for the Jupiter Avionics JA23-001 unit installation as part of a Type Certificate (TC) or Supplemental Type Certificate (STC) project to comply with CAR STD (AWM) 523/527/525/529.1529 or FAR 23/25/27/29.1529 "Instructions for Continued Airworthiness".

Items that may vary by aircraft make and model are shown in brackets ("[]") and should be filled in as appropriate. Some of the checklist items do not apply, in which case they should be marked "N/A" (Not Applicable).

Instructions for Continued Airworthiness, Jupiter Avionics JA23-001 Speaker Amplifier in an [Aircraft Make and Model]

1. Introduction

[Aircraft that has been altered: Registration number, Make, Model and Serial Number]

Content, Scope, Purpose and Arrangement: This document identifies the Instructions for Continued Airworthiness for a Jupiter Avionics JA23-001 installed in an [aircraft make and model].

Applicability: Applies to a Jupiter Avionics JA23-001 installed in an [aircraft make and model].

Definitions/Abbreviations: None, N/A.

Precautions: None, N/A.

Units of Measurement: None, N/A.

Referenced Publications: JA23-001 Installation and Operating Manual
JA23-001 Maintenance Manual
STC/TC # [applicable STC/TC number for the specific aircraft installation]

Distribution: This document should be a permanent aircraft record.



2. Description of the System/Alteration

Jupiter Avionics JA23-001 Speaker Amplifier with interface to external transceivers and [include other equipment/systems as appropriate]. Refer to Appendix A of this manual for interconnect information. Refer to aircraft manufacturer approved interconnect for actual installation.

3. Control, Operation Information

N/A

4. Servicing Information

N/A

5. Maintenance Instructions

Maintenance of the JA23-001 is 'on condition' only. Periodic maintenance is not required. Refer to the JA23-001 Maintenance Manual.

6. Troubleshooting Information

Refer to the JA23-001 Maintenance Manual.

7. Removal and Replacement Information

Refer to Section 2 of this manual - the JA23-001 Installation and Operating Manual. If the unit is removed and reinstalled, a functional check of the equipment should be conducted.

8. Diagrams

Refer to Appendix A of this manual - the JA23-001 Installation and Operating Manual - for installation drawings and interconnect examples.

9. Special Inspection Requirements

N/A

10. Application of Protective Treatments

N/A

11. Data: Relative to Structural Fasteners

JA23-001 and appropriate mounting hardware installation, removal and replacement should be in accordance with applicable provisions of AC 43.13-1B and AC 43.13-2A.

12. Special Tools

N/A

13. This Section is for Commuter Category Aircraft Only

A. **Electrical loads:** Refer to Section 1 of the JA23-001 Installation and Operating Manual.

B. **Methods of balancing flight controls:** N/A.

C. **Identification of primary and secondary structures:** N/A.

D. **Special repair methods applicable to the airplane:** N/A.

14. Overhaul Period

No additional overhaul time limitations.

15. Airworthiness Limitation Section

N/A