



JUPITER AVIONICS
CORPORATION

JA77-015

Switch Plate with Removable Legends
Small Toggle



Installation and Operating Manual

REV A

Jupiter Avionics Corporation
1959 Kirschner Road
Kelowna BC
Canada V1Y 4N7
Tel: +1 778 478 2232
Toll-Free: 1 855 478 2232
www.jupiteravionics.com



Table of Contents

SECTION 1 - DESCRIPTION 1

1.1 System Overview 1

1.2 Features Overview 1

1.3 Inputs and Outputs 1

1.3.1 Inputs 1

1.4 Specifications 1

1.4.1 Electrical Specifications 1

1.4.2 Mechanical Specifications 1

SECTION 2 – INSTALLATION 2

2.1 Introduction 2

2.2 Continued Airworthiness 2

2.3 Unpacking and Inspecting Equipment 2

2.3.1 Warranty 2

2.4 Installation Procedures 2

2.4.1 Installation Limitations 2

2.4.2 Cabling and Wiring 2

2.4.3 Mechanical Installation 3

2.4.4 Legend Replacement 3

2.5 Legend Text Selection using ProCS™ 3

2.5.1 Front Panel Switches 3

2.5.2 Post Installation Checks 4

2.6 Installation Kit 4

2.6.1 Recommended Crimp tool 4

2.7 Installation Drawings 4

SECTION 3 – OPERATION 5

3.1 Introduction 5

3.2 Front Panel Controls 5

3.3 Operation 5

Appendix A - Installation Drawings A1

A1 Introduction A1

A2 Installation Drawings A1

Appendix B - Installation Documents B1

B1 Airworthiness Approval B2

B2 Instructions for Continued Airworthiness B2

JA77-015 Switch Plate with Removable Legends - Small Toggle

SECTION 2 – INSTALLATION

2.1 Introduction

This section contains unpacking and inspection procedures, installation information, and post-installation checks.

2.2 Continued Airworthiness

Maintenance of the JA77-015 is on condition only. Scheduled inspection and/or periodic maintenance of this unit is not required.

2.3 Unpacking and Inspecting Equipment

Unpack the equipment carefully. Check for shipping damage and report any problems to the relevant carrier. Confirm that the Authorized Release Certificate or Certificate of Conformance is included. Complete the on-line warranty card from the Jupiter Avionics Corporation (JAC) website – www.jupiteravionics.com/warranty

2.3.1 Warranty

This product manufactured by JAC is warranted to be free of defects in workmanship or performance for 2 years from the date of installation by an approved JAC dealer or agency. This warranty covers the cost of all materials and labour to repair or replace the unit, but does not include the cost of transporting the defective unit to and from JAC or its designated warranty repair centre, or of removing and replacing the defective unit in the aircraft. This warranty does not cover failures due to abuse, misuse, accident, or unauthorized alteration or repairs.

THIS WARRANTY IS VOID IF THE PRODUCT IS NOT INSTALLED BY AN AUTHORIZED JAC DEALER. If the on-line warranty card is not completed, the product will be warranted from the date of manufacture.

Contact JAC for return authorization, and for any questions regarding this warranty and how it applies to your unit(s). JAC is the final arbiter concerning warranty issues.

2.4 Installation Procedures



CAUTION: The power input circuitry of the unit may be damaged if the installation does not conform to the wiring instructions in this manual.

2.4.1 Installation Limitations

Those installing the JA77, on or in a specific type or class of aircraft, must determine that the aircraft installation conditions are within standards. The JA77 may be installed only by following the applicable airworthiness requirements.

2.4.2 Cabling and Wiring

All wire shall be selected in accordance with the original aircraft manufacturer's maintenance instructions, or AC43.13-1B Change 1, Paragraphs 11-76 through 11-78. Unshielded wire types shall qualify to MIL-W-22759 as specified in AC43.13-1B Change 1, Paragraphs 11-85, 11-86, and listed in Table 11-11. For shielded wire applications, use Tefzel MIL-C-27500 shielded wire with tag ring or equivalent (for shield terminations) to make the most compact and easily terminated interconnect. Follow the Connector Map and Interconnect in Appendix A of this manual.

Maintain wire segregation and route wiring in accordance with the original aircraft manufacturer's maintenance instructions.

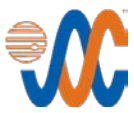

Unless otherwise noted, all wiring shall be a minimum of 22 AWG. Refer to the Interconnect drawing for additional specifications. Check that the ground connection is clean and well secured.

2.4.3 Mechanical Installation

The JA77-015 can be mounted in any attitude and location with adequate space for the front panel and sufficient clearance for the connector and wiring harness. It requires no direct cooling.

2.4.4 Legend Replacement

The JA77-015 illuminated legends are field replaceable. For further information, refer to the 'Legend Replacement' document in Appendix A of this manual.

2.5 Legend Text Selection using ProCS™

The JA77-015 has no required adjustments, but the configuration program ProCS™ can be used to customize the text for each legend either at the time of ordering the unit, or if text changes are required after installation. The JA77-015 need not be connected to a computer to select the legend text.

For information on ordering customized legends, refer to the [ProCS™ Ordering Instructions](#) on the [JAC website](#).

2.5.1 Front Panel Switches

The Front Panel Switches window is used to specify the text for each legend.

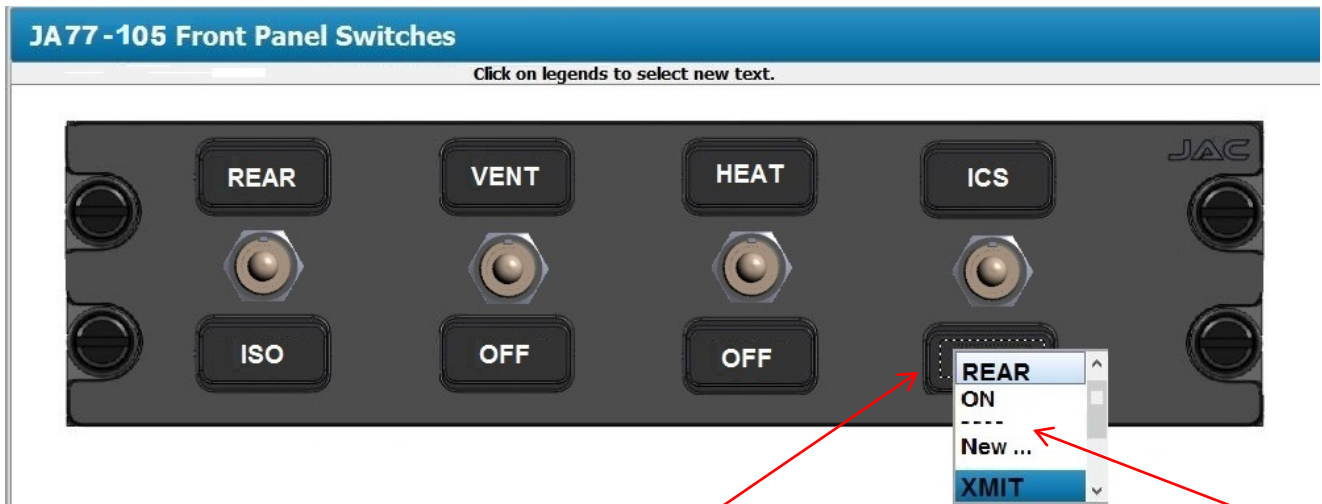

Clicking on a customizable legend will open a **drop-down menu** listing the options for that label. The currently selected option will be highlighted. To escape from the menu, click on the desired option, or right-click in the window. A 'Print...' box will appear. Click outside the box to escape, or select it to print the 'Front Panel Switches' window showing the current label selections.

Among the options is '---' which signifies that the legend will be left blank, and 'New...' which allows the user to enter a completely new legend of up to five characters. If a 'new' legend has been added, the option 'Edit ...' is added to the menu to enable changes to the newly created label.

In the example shown here, the option 'New...' has been selected. A pop-up 'New Label' window will appear, allowing the user to create a customized legend – in this case, JAC. The new legend name will now be shown in the appropriate position on the faceplate representation in the software program.

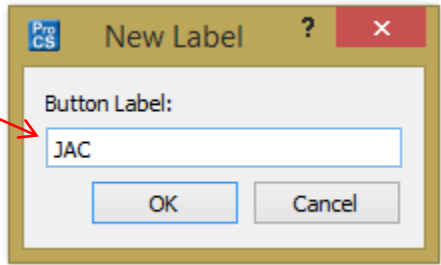



2.5.2 Post Installation Checks

2.5.2.1 Voltage/Resistance checks.

Do not attach this unit until the following conditions are met:

- a) Check P9 pin 1 for +28 Vdc lights buss voltage.
- b) Check P9 pin 2 for continuity to ground (less than 0.5 Ω).
- c) Check all pins for shorts to ground or adjacent pins.

2.5.2.2 Configuration

Ensure that any switches inserted into the JA77-015 are configured correctly. This may be done at the factory, on the maintenance bench or in the aircraft before the power on checks are performed.

2.5.2.3 Power on Checks.

Power up the aircraft's systems and confirm normal operation of all functions controlled by the JA77 switches.

When all performance checks are satisfied, complete the necessary regulatory documentation before releasing the aircraft for service. Refer to [Appendix B](#).

2.6 Installation Kit

The kit required to install this unit is included with the unit.

The installation kit (Part # INST-JA77) consists of the following:

Quantity	Description	JAC Part #
1	Connector Assembly	CON-8500-0001
2	Female crimp pins	CON-8501-0001

2.6.1 Recommended Crimp tool

Micro-Fit Crimp Tool	
Tool Type	Hand crimping tool
MOLEX	63819-0000

2.7 Installation Drawings

The drawings and documents required for Installation can be found in [Appendix A](#) of this manual.

JA77-015 Switch Plate with Removable Legends - Small Toggle

SECTION 3 – OPERATION

3.1 Introduction

This section contains the operating instructions for the JA77-015.

3.2 Front Panel Controls



Note: The eight legends are removable and may be replaced with custom ordered parts.

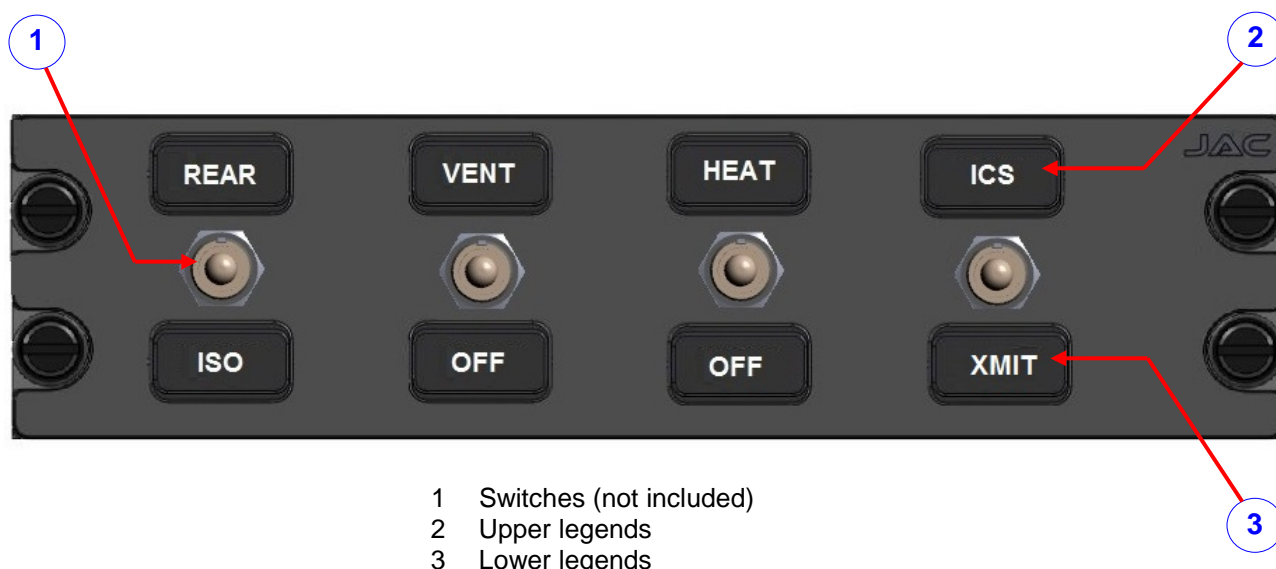

- 1 Switches (not included)
- 2 Upper legends
- 3 Lower legends

The JA77-015 Five Dzus Switch Plate allows the aircraft customizer to present a professional finished configurable switch panel for extra switches. The JA77 accepts standard legends and the legends are removable and available with any text or font.

Blank legends and hole plugs are also available to cover unused switch holes.

3.3 Operation



Note: Check with your installing agency for confirmation of the operation of all switches. The legends are interchangeable to allow customization.

Each switch position is associated with two replaceable legends; one above and one below the switch. The legends will dim with the aircraft lighting buss.



Installation and Operating Manual

Appendix A - Installation Drawings

A1 Introduction

The drawings necessary for installation and troubleshooting of the JA77-015 Switch Plate with Removable Legends - Small Toggle are in this Appendix, as listed below.

A2 Installation Drawings



DOCUMENT	Rev
JA77-015 Connector Map	A
JA77-015 Interconnect	A
JA77-015 Mechanical Installation	CE

Reference Documents	
TOL-CUST-EXTR Legend Replacement	A

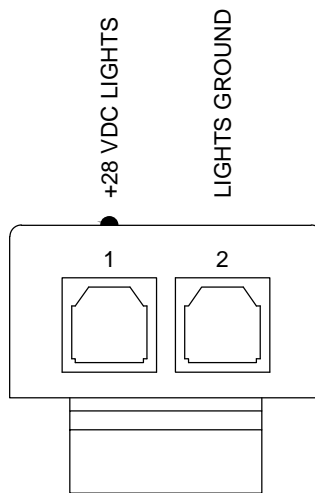
P1
2 PIN FEMALE MICRO-FIT
MATING CONNECTOR



VIEW IS FROM REAR OF MATING CONNECTOR

PREPARED	TAT			
CHECKED				
APPROVED		NCAGE CODE L00N3	PART NO. JA77-015	SHEET 1/1
CONFIDENTIAL & PROPRIETARY TO JUPITER AVIONICS CORP.		DOC NO. JA77-015 Connector Map Rev A.dwg		



JA77-015 INTERCONNECT WIRING NOTES

NOTES

1. ALL WIRE SIZE SHOULD BE 24 AWG MIN UNLESS OTHERWISE SPECIFIED. UNSHIELDED WIRE SHOULD BE SELECTED PER FAA AC43.13-1B CHANGE 1 PARA 11-76 TO 11-78. WIRE TYPES SHOULD BE IN ACCORDANCE WITH MIL-W-22759 AS DESCRIBED IN FAA AC43.13-1B CHANGE 1 PARA 11-85 AND 11-86 AND LISTED IN TABLE 11-11 OR 11-12.

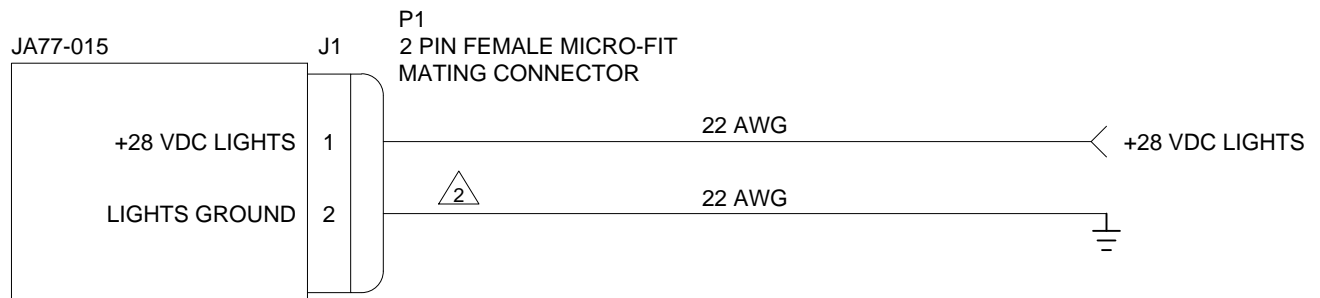
 CONNECTION TO AIRFRAME GROUND SHOULD BE MADE WITH 22 AWG WIRE. LENGTH NOT TO EXCEED 3 FT (0.91 M).



PREPARED	TAT			
CHECKED				
APPROVED		Switches Plate with Removable Legends - Five Dzus Small Toggle		SHEET
CONFIDENTIAL & PROPRIETARY TO JUPITER AVIONICS CORP.		NCAGE CODE	PART NO.	1/1
		L00N3	JA77-015	
		DOC NO. JA77-015 Interconnect Rev A.dwg		

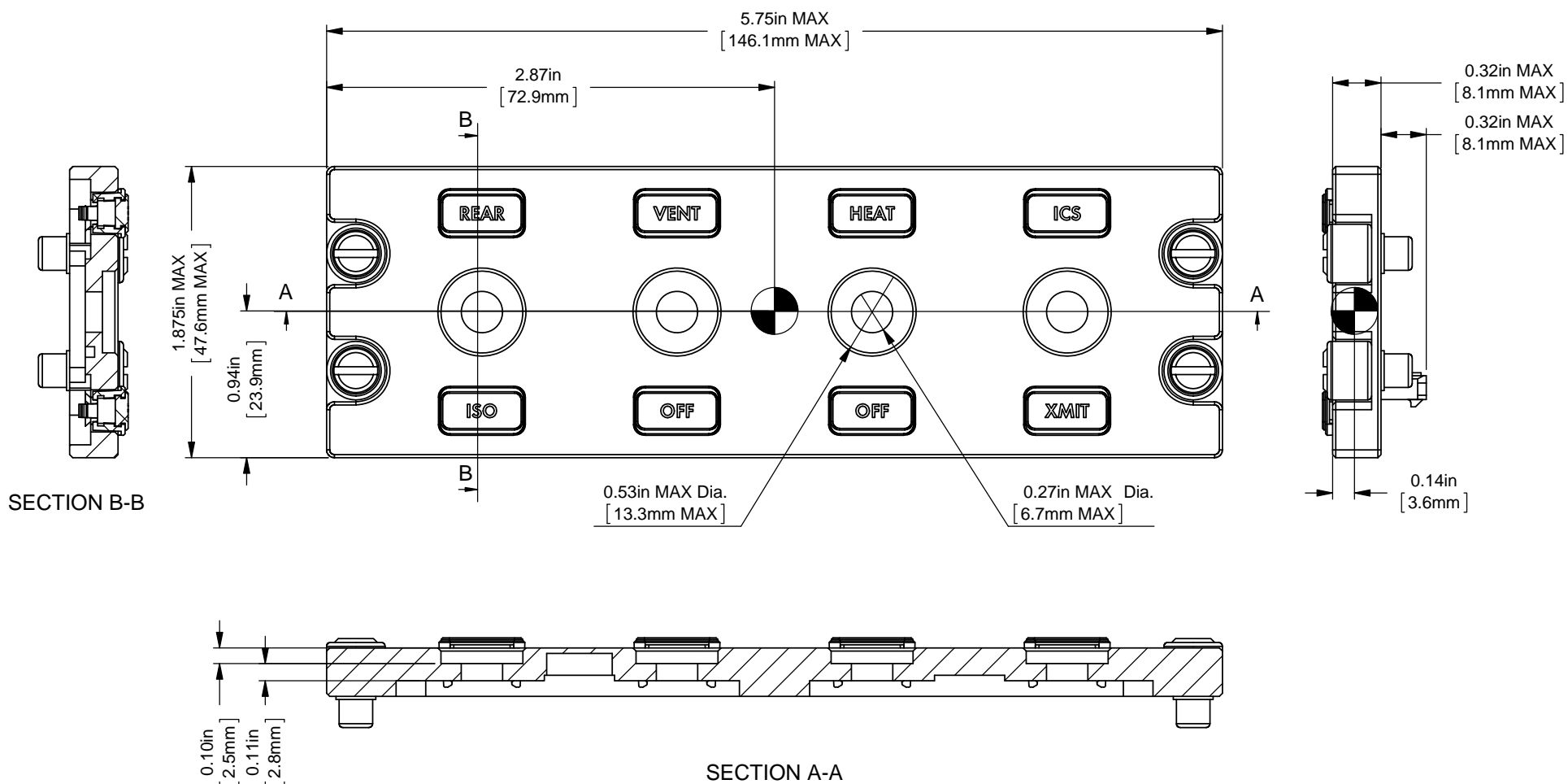

SECTION B-B

SECTION A-A

☉ CENTER OF GRAVITY
±0.03in [0.8mm]

WEIGHT: 0.30 lbs [0.14 kg] MAX.

UNLESS OTHERWISE SPECIFIED
DIMENSIONS ARE IN INCHES
ANGLES ARE IN DEGREES
TOLERANCES:
1 DEC PLACE: ± 0.1
2 DEC PLACE: ± 0.01
3 DEC PLACE: ± 0.005
ANGLES: ± 0.5 DEG

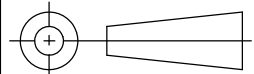

MATERIAL: N/A
FINISH: N/A

PREPARED	TAT
CHECKED	JAC 03-29-17 SRM
APPROVED	JAC 04-03-17 KDV
CONFIDENTIAL & PROPRIETARY TO JUPITER AVIONICS CORP. DRAWING NOT TO SCALE	



TITLE Switches Plate with Removable Legends - Five Dzus - Small Toggle		
NCAGE CODE L00N3	PART NO. JA77-015	SHEET 1/1
DOC. NO. JA77-015 Mechanical Installation Rev A.SLDDRW		



Field-Replaceable Legends

Jupiter Avionics Corporation (JAC) products have field-replaceable illuminated legends. This permits easy customization, and allows the same units to be used in multiple different configurations with only minimal changes.

The internal circuitry ensures that, although the legends are individually illuminated, the illumination is consistent and uniform throughout all legends, and never needs to be balanced. This means that if it is a requirement to change the labelling due to damage or for a different project, there is no need for costly and time-consuming illumination checks.

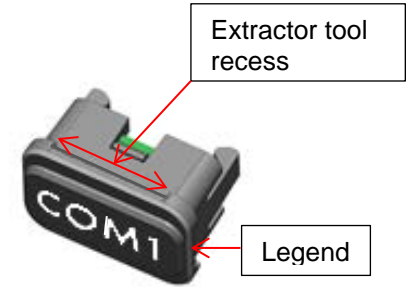

Legend Removal



Caution: Take care not to scratch or otherwise damage the faceplate or the legend.

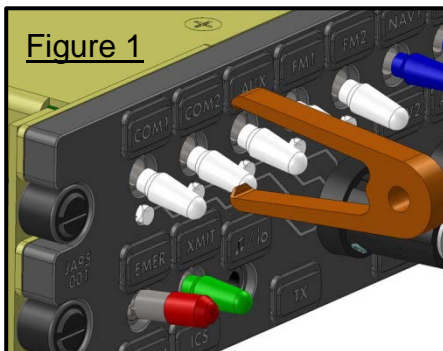

Figure 1

To facilitate legend removal, JAC provides a legend extractor tool - part # TOL-CUST-EXTR (figure 1) that fits into the recesses on the legend.

To remove a legend, hold the extractor firmly between the forefinger and thumb, and use a tweezer-like action to grip the legend (figure 2).

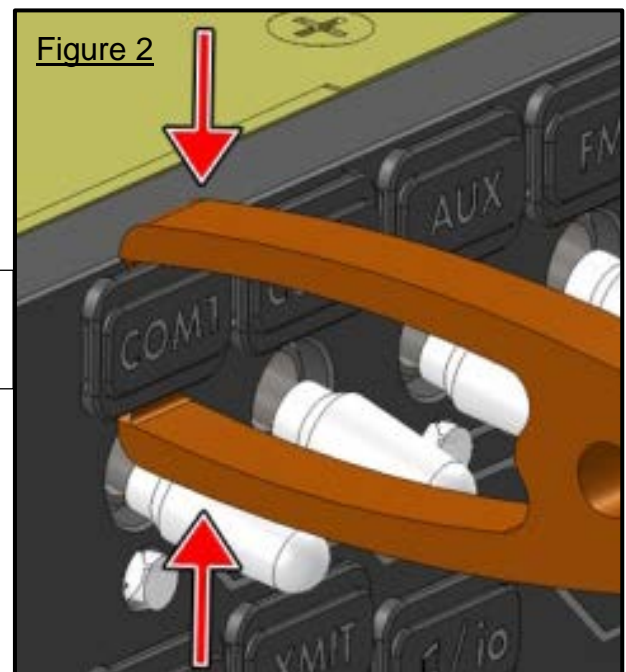

Figure 2

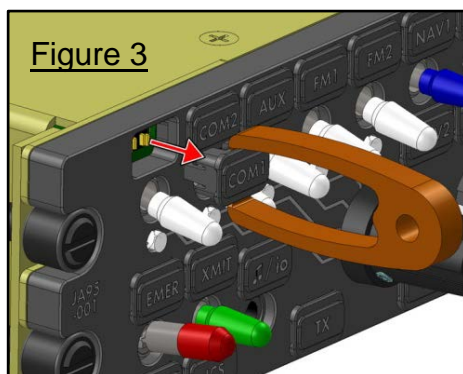

Figure 3

Pull the legend away from the faceplate as shown in figure 3.

Legend Replacement

To replace a legend, align the text correctly, and then apply gentle pressure until the body of the legend support seats firmly into the faceplate.

Once the new legend is in place, ensure that it has seated correctly by checking that it illuminates. The unit is now ready for use.



Installation and Operating Manual

Appendix B - Installation Documents



B1 **Airworthiness Approval**

Airworthiness approval of the JA77-015 may require completion of a TCCA Major Modification Report per CAR STD (AWM) 571 Appendix L, or a FAA Form 337. The sample wording for a description of the work is provided to assist the Installing Agency in preparing Instructions for Continued Airworthiness (ICA) when installing a Jupiter Avionics JA77-015 Switch Plate with Removable Legends - Small Toggle. It is the installer's responsibility to determine the applicability of the method used. Installations performed outside Canada must follow the applicable aviation authority's regulations.

Sample Wording:

Installed a Jupiter Avionics JA77-015 Switch Plate with Removable Legends - Small Toggle in [aircraft location].
Installed in accordance with the JA77-015 Installation Manual, Revision [], and AC 43.13-2, Chapters 2, and 3.
The JA77-015 Installation Manual provides detailed installation instructions and wiring diagrams (Section 2, and Appendices A and B).
Aircraft equipment list, weights and balance amended. Compass compensation checked and found to conform to applicable regulations.

B2 **Instructions for Continued Airworthiness**

Maintenance of the JA77-015 Five Dzus - Switch Plate is "on condition" only. Periodic maintenance of the JA77-015 is not required.

The following sample Instructions for Continued Airworthiness (ICA) provides assistance in preparing ICA for the Jupiter Avionics JA77-015 unit installation as part of a Type Certificate (TC) or Supplemental Type Certificate (STC) project to comply with CAR STD (AWM) 523/527/525/529.1529 or FAR 23/25/27/29.1529 "Instructions for Continued Airworthiness".

Items that may vary by aircraft make and model are shown in brackets ("[]") and should be filled in as appropriate. Some of the checklist items do not apply, in which case they should be marked "N/A" (Not Applicable).

Instructions for Continued Airworthiness, Jupiter Avionics JA77-015 Switch Plate with Removable Legends - Small Toggle in an [Aircraft Make and Model]

1. Introduction

[Aircraft that has been altered: Registration number, Make, Model and Serial Number]

Content, Scope, Purpose and Arrangement: This document identifies the Instructions for Continued Airworthiness for a Jupiter Avionics JA77-015 installed in an [aircraft make and model].

Applicability: Applies to a Jupiter Avionics JA77-015 installed in an [aircraft make and model].

Definitions/Abbreviations: None, N/A.

Precautions: None, N/A.

Units of Measurement: None, N/A.

Referenced Publications: JA77-015 Installation and Operating Manual
STC/TC # [applicable STC/TC number for the specific aircraft installation]

Distribution: This document should be a permanent aircraft record.



2. Description of the System/Alteration

Jupiter Avionics JA77-015 Switch Plate with Removable Legends - Small Toggle. Refer to Appendix A of this manual for interconnect information. Refer to aircraft manufacturer approved interconnect for actual installation.

3. Control, Operation Information

Refer to section 3 of this manual.

4. Servicing Information

N/A

5. Maintenance Instructions

Maintenance of the JA77-015 is 'on condition' only. Periodic maintenance is not required.

6. Troubleshooting Information

N/A

7. Removal and Replacement Information

Refer to Section 2 of this manual - the JA77-015 Installation and Operating Manual. If the unit is removed and reinstalled, a functional check of the equipment should be conducted.

8. Diagrams

Refer to Appendix A of this manual - the JA77-015 Installation and Operating Manual - for installation drawings and interconnect examples.

9. Special Inspection Requirements

N/A

10. Application of Protective Treatments

N/A

11. Data: Relative to Structural Fasteners

JA77-015 and appropriate mounting hardware installation, removal and replacement should be in accordance with applicable provisions of AC 43.13-1B and AC 43.13-2A.

12. Special Tools

N/A

13. This Section is for Commuter Category Aircraft Only

A. **Electrical loads:** Refer to Section 1 of the JA77-015 Installation and Operating Manual.

B. **Methods of balancing flight controls:** N/A.

C. **Identification of primary and secondary structures:** N/A.

D. **Special repair methods applicable to the airplane:** N/A.

14. Overhaul Period

No additional overhaul time limitations.

15. Airworthiness Limitation Section

N/A