



JUPITER AVIONICS
CORPORATION

JA95-043 Audio Controller - AMS43 Compatible



Operating Manual

Rev. A



**Copyright 2015 Jupiter Avionics Corp.
 All rights reserved**

Jupiter Avionics Corporation (JAC) permits a single copy of this manual to be printed or downloaded for personal use. Any such electronic or printed copy of this manual must contain the complete text of this copyright notice. Any unauthorized commercial distribution of this manual is strictly prohibited. Except as described above, no part of this manual may be reproduced, copied, transmitted, disseminated, downloaded, or stored in any storage medium for any purpose without the express prior written consent of JAC.

<p>IMPORTANT:</p> <p>Information in this manual is subject to change without notice.</p> <p>To check the current revision status of this manual, visit the JAC website: www.jupiteravionics.com</p>

Record of Revisions			
Rev	Date	Description	ECR
A	Nov 2015	Initial release, serial number 1001 +	2815

Prepared: MPB	Checked: 	Approved:
----------------------	------------------	-------------------



Table of Contents

1	Introduction	1
2	Front Panel Controls	1
(1)	Transceiver Switches	2
(2)	Receiver Switches	2
(3)	Receive Volume Control	2
(4)	Mode Switch	3
(5)	TAPE/OFF Switch	3
(6)	Music/Configuration Connector (♫/io)	3
(7)	Transmit Annunciator - TX	3
(8)	Transmit Selector	4
(9)	PA Legend	4
(10)	VOX Threshold Control	4
(11)	ICS CALL Annunciator	5
(12)	ICS Volume Control	5
3	Normal Operation Mode	5
3.1	Panel Lighting	5
3.2	Receiving	5
3.3	Transmitting (Transmit Operation)	6
3.4	FM2 PTT Operation	6
3.5	VOX Operation	6
3.6	ICS Operation	6
3.7	Music Operation	6
4	Emergency Operation Mode	7
4.1	Auto Emergency Mode	7
4.2	Selected Emergency Mode	7



1 Introduction

This manual contains the operating instructions for the JA95-043.



Note: The 17 legends and two annunciators are removable and may be replaced with custom ordered parts. For the purpose of this manual the controls will be referred to by the default legend and annunciator names as shown below.

2 Front Panel Controls

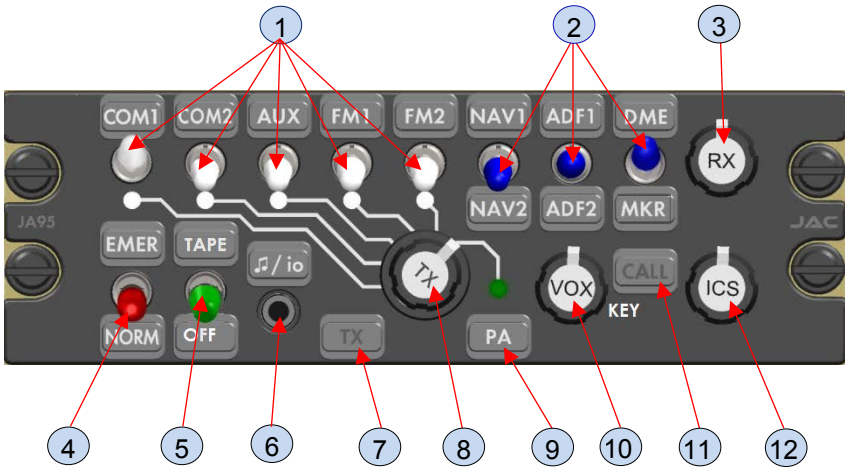

1. Transceiver switches and associated legends
2. Receiver switches and associated legends
3. Receive volume control
4. Mode switch
5. TAPE/OFF switch
6. Music/configuration input connector and legend
7. Transmit annunciator (dead front)
8. Transmit selector
9. PA legend
10. VOX squelch control
11. CALL annunciator (dead front)
12. ICS volume control



(1) Transceiver Switches



These are five white two-position toggle switches. When a switch is set to the 'up' position, audio from the associated transceiver is routed to the phones.

The legends (above the switches) are interchangeable to allow customization. (Default – COM1, COM2, AUX, FM1, FM2, PA.)

(2) Receiver Switches

These are three blue three-position centre-off toggle switches.

When a switch is set to the 'up' or 'down' position audio from the selected receiver is routed to the phones.



The legends (three above and three below the switches) are interchangeable to allow customization. (Default – NAV1, NAV2, ADF1, ADF2, MKR, DME.)

(3) Receive Volume Control

This is a rotary knob that adjusts the phones volume of the receive audio from minimum at fully counterclockwise (CCW) to maximum when fully clockwise (CW). Individual radio volume controls should be set to a nominal level, and then adjusted for changing flight conditions using this control.





(4) Mode Switch

This is a red two-position locking toggle switch. When set to the 'up' position, the unit is Emergency mode, and when set to the 'down' position, the unit is in Normal mode. The legends are interchangeable to allow customization. (Default – EMER, NORM.)



The switch is lockable to prevent accidental changing of the mode. The switch must be lifted to release the lock.

For full information on Normal and Emergency Mode operation, see [section 3](#) and [section 4](#) below.

(5) TAPE/OFF Switch



This is a green two-position toggle switch.

Moving the TAPE/OFF switch into the OFF position causes the music input - either from the rear tape input or from the front panel music input or both - to be muted. Placing the switch in the TAPE position causes the music to be unmuted.

(6) Music/Configuration Connector (♫/io)

This is a music input that is compatible with most music players. It accepts a 3 pole 3.5mm stereo plug with a slim diameter connector housing.

(This connector port is also used during installation to change configuration settings.)



CAUTION: If an unapproved connector or cable is used, damage to the unit or to any attached device may occur. Contact JAC for a list of approved cables, music sources and devices.

(7) Transmit Annunciator - TX

This is a dead-front annunciator that will illuminate when the unit is transmitting.

The default legend is 'TX', but it is interchangeable to allow customization.

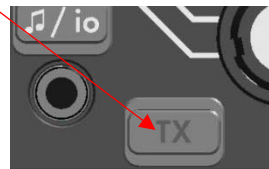



(8) Transmit Selector

This is a rotary six-position control that is used to select transmission via one of the five transceivers or the public address system (PA).



Each of the transmit selector positions is linked by a white line to the corresponding transmit select annunciator, transceiver switch and legend.

The appropriate annunciator will light **green** to show which transceiver is selected for transmit - 'PA' in this example.

(9) PA Legend

This is a customizable legend to mark the PA position for the transmit selector.

The interchangeability allows an appropriate name for this legend to be selected.

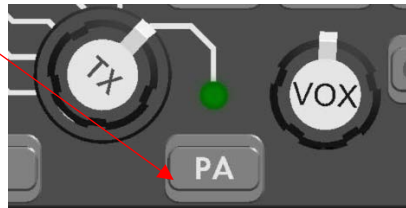

(10) VOX Threshold Control

This is a rotary knob used to select the VOX threshold of the unit. See below.

When rotated fully cw, the threshold will be at maximum and VOX ICS operation is disabled and ICS PTT input is required for ICS operation.

When rotated fully ccw, the threshold will be at minimum (almost live).

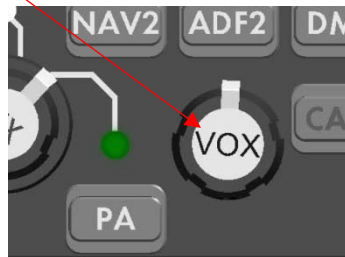

To adjust the unit for **VOX** (Voice activated) use, the VOX control should be set fully ccw and then slowly rotated cw to the point where no intercom audio can be heard. The VOX control should be adjusted for proper operation according to the ambient noise.



(11) ICS CALL Annunciator

This is a customizable dead-front annunciator activated by an external switch. The legend is interchangeable to allow customization.

When enabled, it will illuminate when a ground is applied to the ICS CALL input from another user's Audio Controller or by a remote 'call' button within the aircraft.



Note: Check with your installing agency for confirmation of the operation of this annunciator.

(12) ICS Volume Control

This is a rotary control used to adjust the volume of all ICS audio to suit the ambient conditions. Rotating the control completely cw gives rated level, and completely ccw reduces the output to minimum level.



3 Normal Operation Mode



Note: Numbers in parentheses refer to the front panel controls shown in section 2.

The JA95-043 is in Normal mode when the front panel EMER / NORM switch (4) is in the NORM position and suitable electrical power is supplied to the unit.

3.1 Panel Lighting

The legends and annunciators will be illuminated (when appropriate) and dim through the aircraft lighting buss.

3.2 Receiving

When the JA95-043 receives an incoming transmission on a transceiver or receiver that has been selected, either by the white transceiver receive switches (1) or the transmit selector (8), the incoming audio will be directed to the user's phones.

The audio level of any incoming transmission will depend upon the level selected by the front panel RX volume control (3). It will be muted if the unit is transmitting and muting of receive audio during transmit is enabled.



3.3 Transmitting (Transmit Operation)

To select a transceiver, rotate the Transmit Select Switch until it aligns with the line leading to the Transceiver Select switch legend (see **1**) - default legends COM1, COM2, AUX, FM1, FM2, or PA. The corresponding Transmit Select annunciator will illuminate.

When the user's TX PTT is activated, the unit will transmit on the selected transceiver, and the deadfront Transmit Annunciator (**7**) will illuminate 'TX'. All MIC and sidetone audio will be routed to the user's phones, and any music will be muted for the duration of the transmission.

3.4 FM2 PTT Operation



Note: If the FM2 transceiver has been configured as duplex, it can be used with a cellphone or sat-phone. Check your configuration with the installing agency.

If the unit has been configured for cellphone or sat-phone use and FM2 has been selected for transmit, momentarily activating the TX PTT (either from the faceplate or by some other method) will keep FM2 transmitting. A second momentary activation of the TX PTT, or moving the Transmit Selector away from FM2, will stop FM2 from transmitting.

3.5 VOX Operation

A user's MIC audio is routed to the ICS when the MIC audio level exceeds the VOX threshold.

A user's MIC audio is disconnected from the ICS when the MIC audio level falls below the VOX threshold for 0.5 to 2 seconds.

3.6 ICS Operation

ICS audio is the sum of all the MIC audio from users with ICS KEY active or with MIC audio level exceeding the VOX Threshold level.

The ICS audio also includes the audio input on the ICS TIE from other Audio Controllers.

The ICS audio is output on the phones of each user.

The ICS audio is muted during transmit.

The ICS audio level at the phones is controlled by the ICS volume control (**12**).

3.7 Music Operation

Music to the headphones will be muted by incoming audio (ICS, Receive, Direct or Alert Audio) or if the unit is transmitting. When the incoming audio has ended, the music will gradually return to the previous level.



4 Emergency Operation Mode

Emergency mode can be selected by the Mode switch on the front panel, or entered automatically if power to the unit is lost.

4.1 Auto Emergency Mode

If the unit is in emergency mode because power has been lost to the unit, the sum of the COM1 transceiver, NAV1 receive, and DIRECT AUDIO will be routed to the pilot's phones. The pilot's microphone and transmit key are connected to the COM1 transceiver. No other function in the JA95-043 will operate when power is lost. Indicator LEDs, legends and annunciators will not be illuminated.

4.2 Selected Emergency Mode

If the unit is in emergency mode because the EMER / NORM switch is in the EMER position and sufficient power is applied to the JA95-043, the sum of the COM1 receive, NAV1 receive, DIRECT AUDIO and Alert audio will be routed to the pilot's phones. The pilot's microphone and transmit key are connected to the COM1 transceiver. The pilot is disconnected from the ICS. The COM1 transceiver and NAV1 receiver and DIRECT AUDIO are not available to the other users. All other functions of the JA95-043 will operate. The LEDs, legends and annunciators will retain normal functionality.



JUPITER AVIONICS
CORPORATION

Jupiter Avionics Corporation
1959 Kirschner Road
Kelowna BC
Canada V1Y 4N7
Tel: 778-478-2232
Toll-Free: 855-478-2232
www.jupiteravionics.com