



JUPITER AVIONICS
CORPORATION

wi JAC2™-001 (JB60/JB69)

Wireless Intercom System - N America



Operating Manual

Rev B

Jupiter Avionics Corporation
1959 Kirschner Road
Kelowna BC
Canada V1Y 4N7
Tel: +1 778 478 2232
Toll-Free: 1 855 478 2232
www.jupiteravionics.com

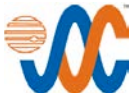

Table of Contents

1	Introduction	1
1.1	Unpacking	1
1.2	Verify Operating Region	1
1.3	Verify Pairing Registration Number	2
2	The wiJAC2-001 Components	2
2.1	JB60-001 Headset Adapter (JB60)	3
2.1.1	JB60 Controls	3
2.1.2	JB60 Connectors	4
2.1.3	JB60 Annunciators	4
2.1.4	JB60 Internal Adjustments, Annunciators and Connectors	5
2.2	JB69-001 Intercom Adapter (JB69)	6
2.2.1	JB69 Controls	6
2.2.2	JB69 Connectors	6
2.2.3	JB69 Annunciators	6
2.2.4	JB69 Internal Adjustments, Annunciators and Connectors	7
2.3	Other Features (Both units)	8
2.3.1	Battery Lid Release	8
2.3.2	Belt Clip	8
2.3.3	Hook and Loop Fastener Mounting	8
2.4	Batteries (for both JB60 and JB69)	9
2.4.1	Inserting or Replacing the Batteries	9
2.4.2	Charging Batteries in the Unit	9
2.4.3	Charging Operation – via Battery Charger	9
2.4.4	Battery Cautions and Warnings	10
3	Connecting the wiJAC™ System	11
3.1	wiJAC™ Set-up and Connection	12
3.1.1	Insert Batteries	12
3.1.2	Attach Connectors to Aircraft and Headset	12
3.1.3	Turn On Adapters and Verify Connection	12
3.1.4	Verify Audio Operation	12
3.2	wiJAC™ Adjustments and Pairing	13
3.2.1	Pairing Process	13
4	wiJAC™ System Operation	14
4.1	Overview	14
4.1.1	Listening Operation	14
4.1.2	VOX Speaking Operation	14
4.1.3	ICS PTT Speaking Operation	14
4.1.4	Live Speaking Operation	14
4.1.5	Low Battery Warning	14
4.1.6	Operation during Charging	14
4.1.7	Loss of Audio	14
4.1.8	Battery Life	15
5	Compliance Statements	15
5.1	FCC compliance statement	15
5.2	Industry Canada compliance statement	15



1 Introduction

This manual contains the operating instructions for the **wiJAC2-001** Wireless Intercom Dropcord System.

The diagram below describes the naming method for the different systems.

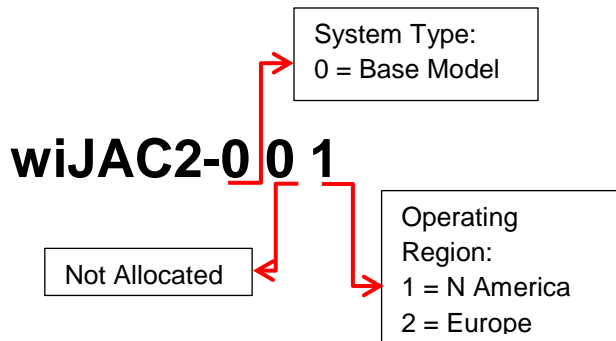

N America:

The **wiJAC2-001** consists of one JB60-001 Wireless Aircraft Headset Adapter, and one JB69-001 Wireless Aircraft Intercom adapter.

RF output power is 21 dBm (125 mW peak)

Channel frequencies	23 =	1.921536 GHz
	24 =	1.923264 GHz
	25 =	1.924992 GHz
	26 =	1.926720 GHz
	27 =	1.928448 GHz

Only paired units will operate together (see [section 1.3](#))

System operating information is in [section 4](#).



WARNING: JAC recommends that no battery-operated device should be relied upon as the sole method of communication in cases where there is potential risk to life or limb.

1.1 Unpacking

Unpack the **wiJAC2™** box carefully, and ensure that it contains the following:

- one ea. Wireless Aircraft Headset Adapter, JAC P/N JB60-001
- one ea. Wireless Aircraft Intercom Adapter, JAC P/N JB69-001
- one ea. CAB-HSET-0001 Headset Adapter Cable
- one ea. CAB-WJ2-0004 Audio Panel Intercom Adapter Cable (10pin Hirose plug to U174 plug)
- one **wiJAC2-001** User Quick Start Guide, JAC P/N DOC-GUID-WI2001

1.2 Verify Operating Region

The **wiJAC2-001** Wireless Intercom System operates using radio frequencies that are authorized by government regulatory agencies. Ensure the region in which you are operating the units matches the region marked on a label on the back of each unit.



1.3 Verify Pairing Registration Number

The **wiJAC™** Wireless Intercom System consists of one set of paired Adapters. The JB60-001 Headset Adapter and JB69-001 Intercom Adapter will only operate together when paired. Refer to the Pairing Instructions in [section 3.2](#).

2 The wiJAC2-001 Components



The wiJAC2-001 consists of two main components – the JB60-001 Headset Adapter and the JB69-001 Intercom Adapter.

The headset is not included.

2.1 JB60-001 Headset Adapter (JB60)

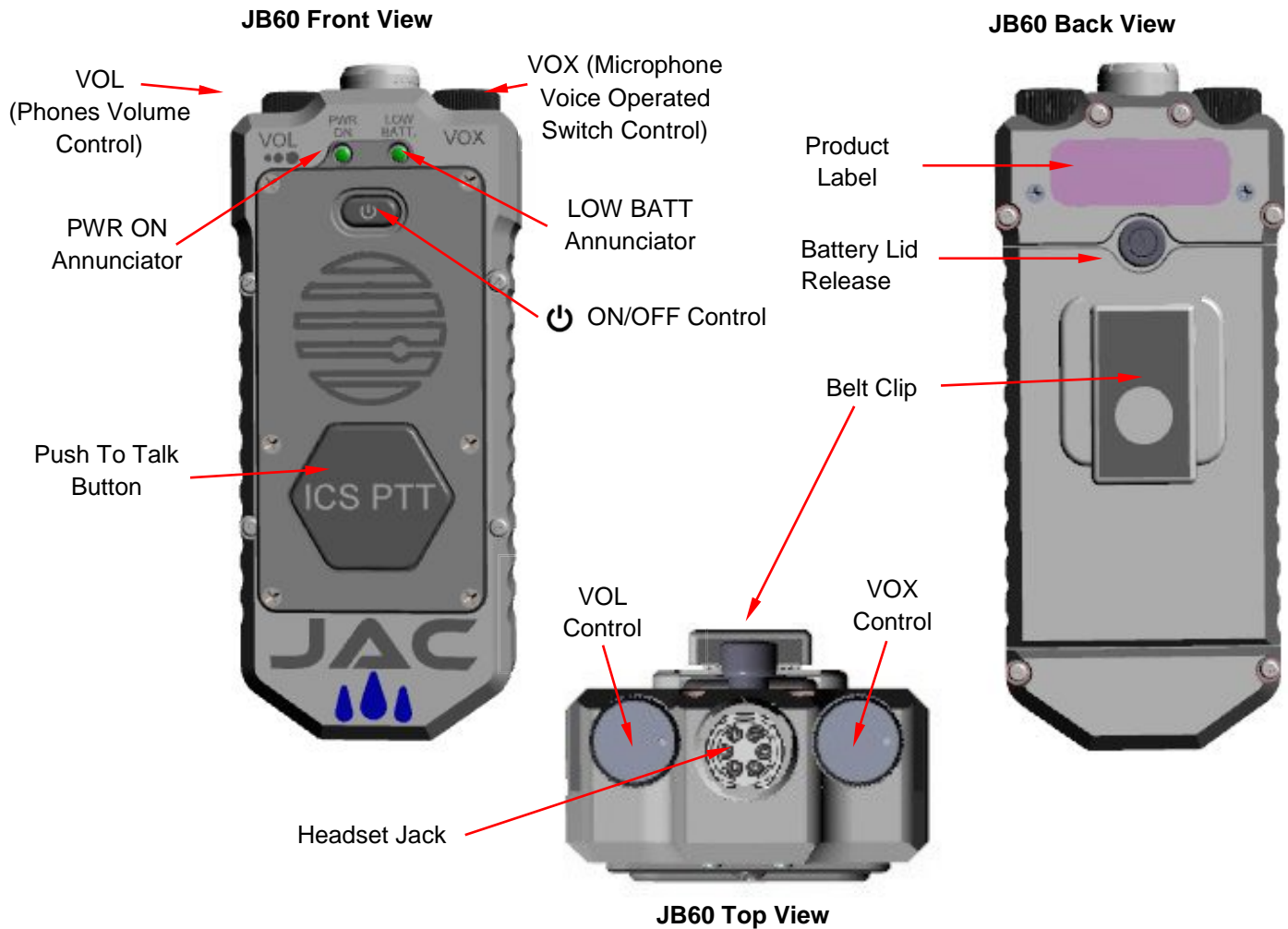

Note: The unit is shown in grey for clarity.

2.1.1 JB60 Controls

2.1.1.1 (ON/OFF) Button

The ON/OFF control is a push button switch marked with the symbol and is located at the centre top of the unit front. To turn the unit on, press the ON/OFF button once. The PWR ON annunciator will illuminate green, and the LOW BATT annunciator will illuminate for two seconds as the JB60 starts searching for a paired JB69.

To turn the unit off, press and hold the ON/OFF button for approximately 3 seconds. (The PWR ON annunciator will turn off and the LOW BATT annunciator will illuminate red and then turn off as the JB60 turns off, or when the ON/OFF button is released.)

2.1.1.2 **VOX** (Voice Operated Switch)

The Voice Operated Switch control is a rotary knob marked VOX located on the top right of the JB60-001 Headset Adapter. To reduce the level of the sound needed to route the microphone audio to the Intercom Adapter, turn the VOX knob counterclockwise (ccw). To increase the level of the sound needed to route the microphone audio to the Intercom Adapter, turn the VOX knob clockwise (cw). When the control is at the detent in the fully cw position, the unit will be in PTT ICS mode. Adjust this setting for proper VOX operation as ambient noise levels change.



2.1.1.3 VOL (Phones Volume Control)



WARNING: Loud noise can cause hearing damage. Before using the headset, set the volume to minimum, and then slowly increase it to a comfortable listening level.

The volume control is a rotary knob marked VOL (volume) located on the top left of the JB60-001 Headset Adapter. To reduce the volume of the audio heard in the headset rotate the VOL knob counterclockwise. To increase the volume of the audio heard in the headset rotate the VOL knob clockwise.

2.1.1.4 ICS PTT (Push To Talk) Button

The intercom Push To Talk button is a hexagonal push button switch marked ICS PTT located on the upper front of the JB60-001 Headset Adapter. When the ICS PTT button is pressed and held, the VOX threshold is overridden, microphone audio is routed to the paired Intercom Adapter, and the ICS Key output is also activated.

2.1.2 JB60 Connectors

2.1.2.1 Headset Jack

The headset jack is a 6 pin Hirose jack on the top of the JB60-001 headset adapter. An appropriate mating headset connector can be inserted directly into the jack

2.1.3 JB60 Annunciators

2.1.3.1 PWR ON (Power On)

The power on (PWR ON) annunciator is a green LED located on the front left of the unit.

- When a unit is turned on, the PWR ON annunciator will illuminate for 2 seconds, and the unit will start to search for its paired unit.
- While the unit is searching for its paired unit the PWR ON annunciator will triple-flash every 1.5 seconds.
- When the unit is connecting to its paired unit, the annunciator will double-flash every 1.5 s until connection is established,
- After connection, the annunciator will illuminate steady green until the unit is turned off.

2.1.3.2 LOW BATT (Low Battery Warning)

The low battery (LOW BATT) warning annunciator is a red LED located on the front right of the unit. When the unit is turned on, the LOW BATT annunciator will illuminate for 2 seconds.

When the JB60 battery voltage is low the LOW BATT annunciator will flash once every 1.5 s and output a low battery notification (a triple beep) in the headphones once every minute until the battery charge reaches critical voltage level. (A similar but higher pitched tone will be heard if the paired JB69 Intercom Adapter battery charge is low.)



Note: JAC recommends that the batteries should be charged or replaced immediately if the LOW BATT warning illuminates during use.

When the unit battery charge is less than or equal to the critical battery voltage, the unit will turn off.

2.1.4 JB60 Internal Adjustments, Annunciators and Connectors

To reveal the internal adjustments, annunciators and connectors, remove the battery cover by unfastening the thumbscrew on the rear of the unit and raising the top of the cover until it can be lifted clear of the retaining tabs.



CAUTION: To prevent potential damage or loss of function, the internal adjustments, controls and CONFIG port should **only** be used at initial set up. Contact your installing agency for any required changes.

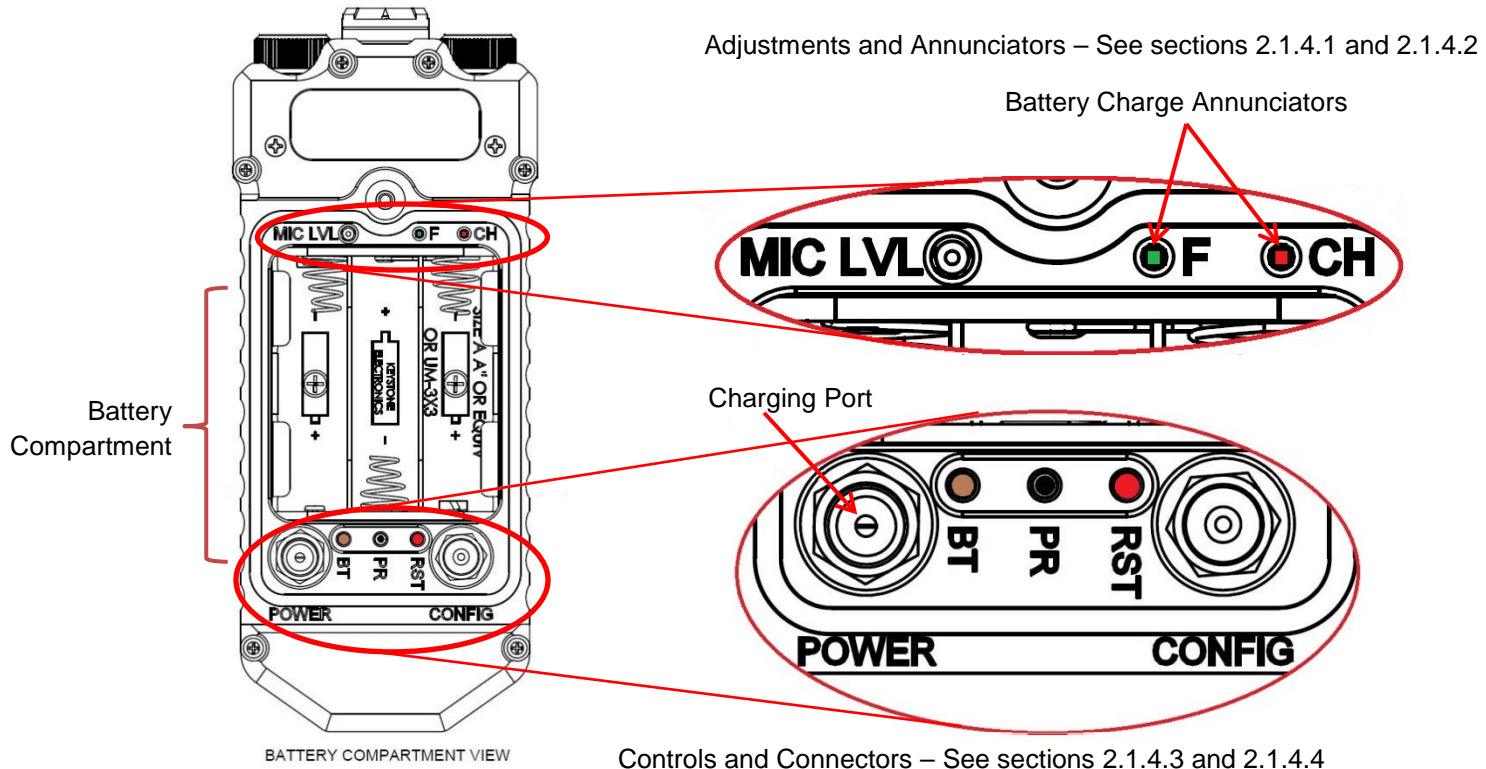

Adjustments and Annunciators – See sections 2.1.4.1 and 2.1.4.2

Battery Charge Annunciators

Charging Port

Controls and Connectors – See sections 2.1.4.3 and 2.1.4.4

2.1.4.1 Adjustments

The MIC INPUT signal (**MIC LVL**) should only be adjusted by qualified technical personnel.

2.1.4.2 Annunciators

Battery Charge

The JB60-001 Battery Charge annunciators are two LEDs at the top right of the battery compartment.

The Charging annunciator (**CH**) is a red LED that will illuminate when the batteries are being charged at the maximum charge current, and the Full Charge (**F**) annunciator is a green LED that will illuminate when the batteries are fully charged.

2.1.4.3 Controls

These buttons are recessed to prevent accidental activation. The Boot (**BT**) and Reset (**RST**) buttons should only be activated by qualified technical personnel.

2.1.4.4 Connectors

POWER (Charging Port)

The Charging Port (marked **POWER**) is a 2.1 mm coaxial jack on the bottom left side of the battery compartment. To charge NiMH batteries, connect a USB (Universal Serial Bus) to Micro USB cable from the Charging Port to a USB power source.

CONFIG (Mode Select)

The Configuration Port (marked **CONFIG**) on the bottom right side of the battery compartment is for factory use only.

2.2 JB69-001 Intercom Adapter (JB69)

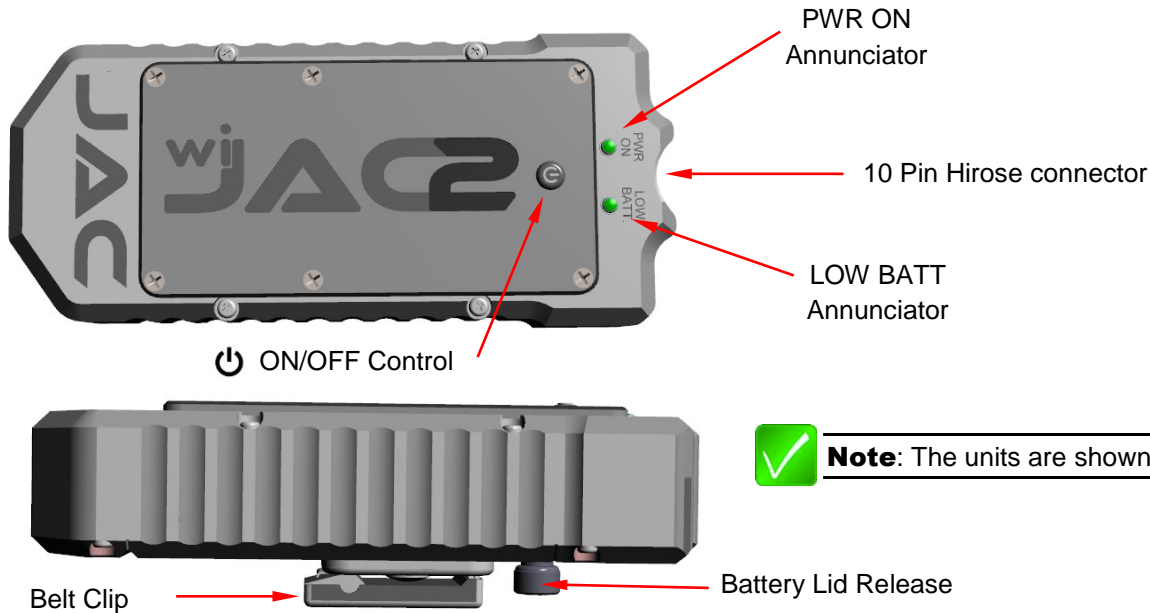

2.2.1 JB69 Controls

2.2.1.1 (ON/OFF) Button

The ON/OFF control is a push button switch marked with the symbol and located at the front centre top of both units. To turn the unit on, press the ON/OFF button once. The PWR ON annunciator will illuminate green, and the LOW BATT annunciator will illuminate for two seconds as the units start to search for its paired unit.

To turn the unit off, press and hold the ON/OFF button for approximately 3 seconds. (The PWR ON annunciator will turn off and the LOW BATT annunciator will illuminate red and then turn off as the unit turns off, or when the ON/OFF button is released.)

2.2.2 JB69 Connectors

2.2.2.1 Intercom Connector

The JB69-001 Intercom Adapter connects to the aircraft audio panel via a 10 pin Hirose Connector.

2.2.3 JB69 Annunciators

2.2.3.1 PWR ON (Power On)

The power on (PWR ON) annunciator is a green LED located on the front left of the unit.

- When a unit is turned on, the PWR ON annunciator will illuminate for 2 seconds, and the unit will start to search for its paired unit.
- While the unit is searching for its paired unit the PWR ON annunciator will triple-flash every 1.5 seconds.
- When the unit is connecting to its paired unit, the annunciator will double-flash every 1.5 s until connection is established,
- After connection, the annunciator will illuminate steady green until the unit is turned off.

2.2.3.2 LOW BATT (Low Battery Warning)

The low battery (LOW BATT) warning annunciator is a red LED located on the front right of the unit. When the unit is turned on, the LOW BATT annunciator will illuminate for 2 seconds.



When the JB69 battery voltage is low the LOW BATT annunciator will flash once every 1.5 s and output a low battery notification (a triple beep) in the headphones once every minute until the battery charge reaches critical voltage level. (A similar but lower pitched tone will be heard if the paired JB60 Headset Adapter battery charge is low.)



Note: JAC recommends that the batteries should be charged or replaced immediately when the LOW BATT warning illuminates during use.

When the unit battery charge is less than or equal to the critical battery voltage, the unit will turn off.

2.2.4 JB69 Internal Adjustments, Annunciators and Connectors

To reveal the internal adjustments, annunciators and connectors in the battery compartment, remove the battery cover by unfastening the thumbscrew on the rear of the unit and raising the top of the cover until it can be lifted clear of the retaining tabs.



CAUTION: To prevent potential damage or loss of function, the internal adjustments, controls and CONFIG port (*information italicized*) should **only** be used by qualified technical personnel. Contact your installing agency for any required changes.

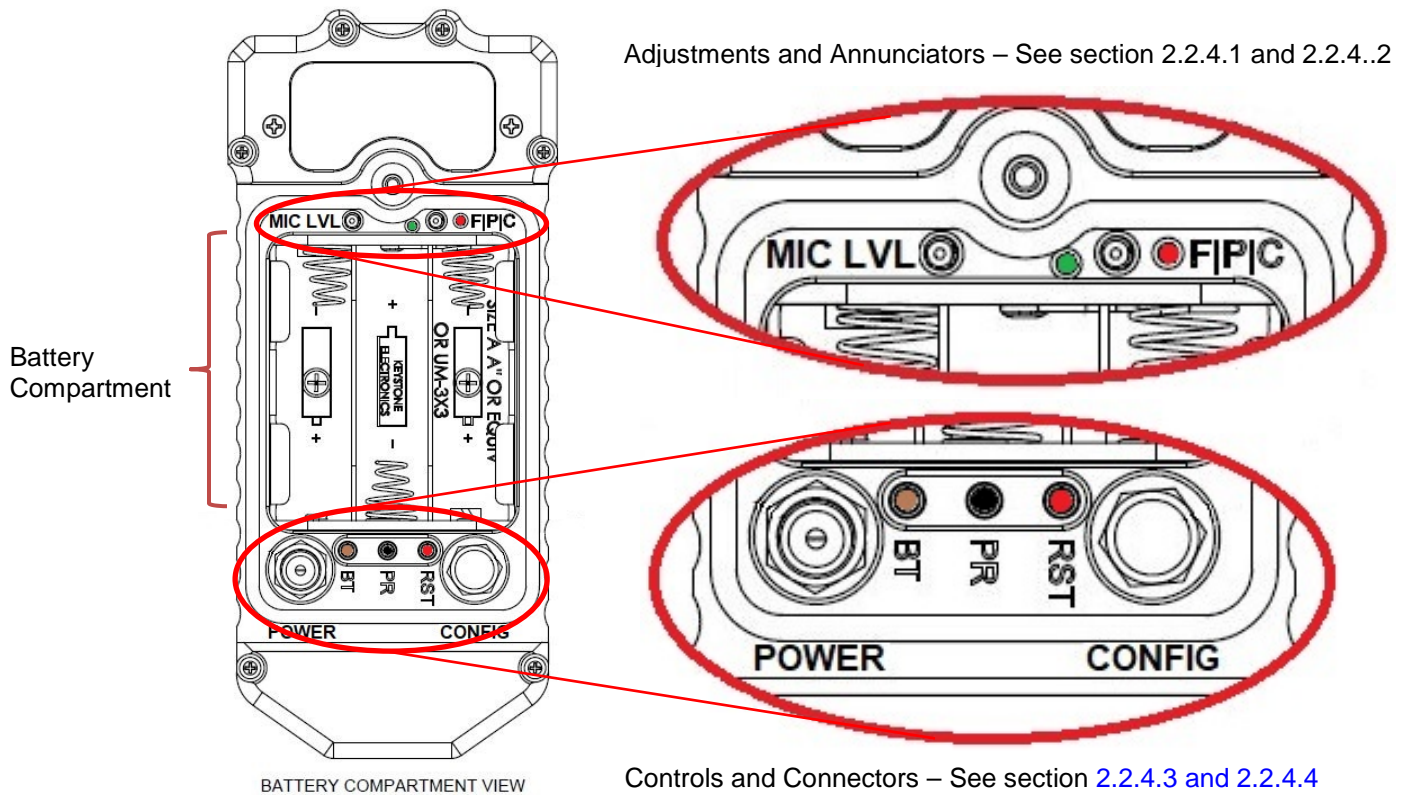

2.2.4.1 Adjustments

The MIC INPUT signal (**MIC LVL**) and Phones Level signal (**P**) should only be adjusted by qualified technical personnel.

2.2.4.2 Annunciators

Battery Charge

The JB69-001 Battery Charge annunciators are two LEDs at the top right of the battery compartment.

The Charging annunciator (**C**) is a red LED that will illuminate when the batteries are being charged at the maximum charge current, and the Full Charge (**F**) annunciator is a green LED that will illuminate when the batteries are fully charged.



2.2.4.3 Controls

*These buttons are recessed to prevent accidental activation. The Boot (**BT**) Pair (**PR**) and Reset (**RST**) buttons should only be adjusted by qualified technical personnel.*

2.2.4.4 Connectors

POWER (Charging Port)

The Charging Port (marked **POWER**) is a 2.1 mm coaxial jack on the bottom left side of the battery compartment. To charge NiMH batteries, connect a USB to Type M 2.1 mm Plug from the Charging Port to a USB power source.

CONFIG (Mode Select)

The Configuration Port (marked CONFIG) on the bottom right side of the battery compartment is for factory use only.

2.3 Other Features (Both units)

2.3.1 Battery Lid Release

The battery compartment lid release is a thumbscrew on the rear of the unit.

2.3.2 Belt Clip

The belt clip is on the rear of both the JB60-001 Headset Adapter. Ensure that the units are attached securely.

2.3.3 Hook and Loop Fastener Mounting

The loop side of the fastener is on the rear of the JB69-001 Intercom Adapter.

The hook side of the fastener is included with the unit. Ensure the mounting surface is clean before installation.



2.4 Batteries (for both JB60 and JB69)



WARNING: Charging battery types other than NiMH or NiCad may cause the batteries to leak or explode and cause damage or injury. If non-NiMH or non-NiCad batteries are installed, do not connect the Charging Port to a USB power source.

The JB60-001 and JB69-001 each require three AA batteries. JAC recommends Duracell 800 mAh (or higher) NiMH or Duracell alkaline batteries for use in the **wiJAC2™** system to obtain the typical battery life.

Removal of the batteries WILL NOT change any internal configuration of the unit.

2.4.1 Inserting or Replacing the Batteries

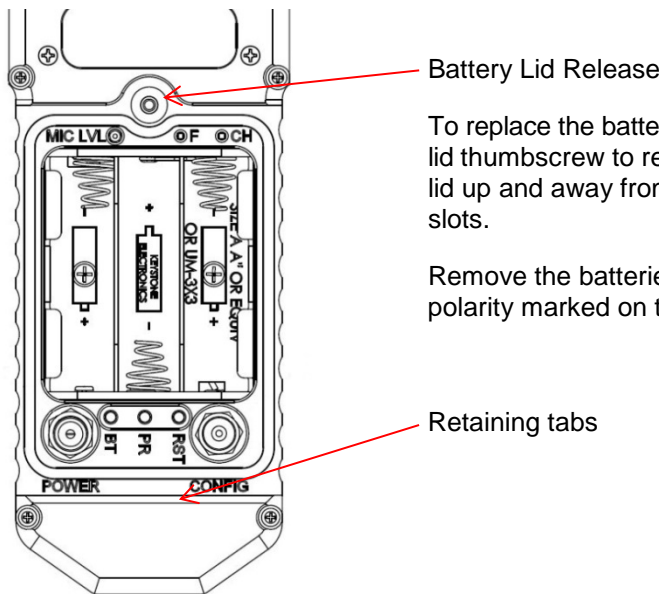

Battery Lid Release

To replace the batteries, remove the battery cover by unfastening the battery lid thumbscrew to release the upper end of the cover, and then gently lift the lid up and away from the body to release the two retaining tabs from the slots.

Remove the batteries and insert new or fully charged batteries, matching the polarity marked on the battery holder.

Retaining tabs

2.4.2 Charging Batteries in the Unit

To charge rechargeable batteries in the unit, connect the Charging Port to a USB power source using the USB to 2.1 mm male cable (CAB-USB-0013). If turned on during charging, the unit draws its power from the charging source, not the batteries, but battery charging will take longer. When charging is complete, the 'Full' annunciator (F) will illuminate green.

It should be possible to charge the unit via most USB power sources but this cannot be guaranteed for any products not made by or purchased from JAC.



Note: The batteries will charge whether the JB60/JB69 is switched on or switched off. Battery charging will take longer if the unit is switched on.

2.4.3 Charging Operation – via Battery Charger

The batteries may be removed from the unit for charging in a separate battery charger. Removal of the batteries WILL NOT change any internal configuration of the unit.



Note: The JB60/JB69 will only charge the batteries when the internal temperature is within 0 to 40 °C



2.4.4 Battery Cautions and Warnings



CAUTION: Follow these guidelines to prolong battery life and minimize the risk of unit malfunction.

- ⚠ Do not leave battery uncharged for long periods of time.
- ⚠ Do not leave battery charging for extended periods (more than 48 hours)
- ⚠ To ensure that the unit functions correctly, insert the new batteries with the positive and negative poles aligned as indicated in the battery compartment.
- ⚠ When replacing the batteries, use only new or fully charged batteries.
- ⚠ Do not mix old and new batteries as this can cause battery leakage and/or damage to the unit.
- ⚠ Do not mix battery types.



WARNING: Follow these guidelines to prolong battery life, and minimize the risk of fire, chemical burns, electrolyte leaks and/or injury.

- ❗ **FOLLOW** the manufacturer's instructions for care and disposal of batteries.
- ❗ **DO NOT** use sharp objects to remove the batteries.
- ❗ **DO NOT** disassemble, puncture, burn or in any other way damage the batteries.
- ❗ **DO NOT** let children handle the batteries.
- ❗ **USE ONLY** approved battery chargers.
- ❗ **USE ONLY** approved replacement batteries.



3 Connecting the wiJAC™ System



Note: The wiJAC2-001 Wireless Intercom Dropcord System consists of one JB60-001 Headset Adapter and one JB69-001 Intercom Adapter. Only paired units will operate together (see [section 3.2.1](#))

The JB69-001 Intercom Adapter is connected via an adapter cable (CAB-WJ2-0004) into a jack in the aircraft where the headset dropcord is normally connected, and is then clipped to a suitable point in the aircraft.

A headset is inserted (via adapter cable CAB-HSET-0001 if required) into the jack on the JB60-001 Headset Adapter, which is clipped to the user's belt or clothing. **Headset and audio panel are not included.**



WARNING: JAC recommends that no battery-operated device should be relied upon as the sole method of communication in cases where there is potential risk to life or limb.

ALWAYS charge rechargeable batteries before every use.



JB60-001 Headset Adapter
(Connected to user's headset)

JB69-001 Intercom Adapter
(Plugged in to aircraft intercom jack)



3.1 wiJAC™ Set-up and Connection

3.1.1 Insert Batteries

Ensure the batteries for both units are either **new** or **fully charged**, and installed in the battery compartment with the correct polarity, and that the battery lid is secured (see [section 2.4](#)).

3.1.2 Attach Connectors to Aircraft and Headset

Connect the JB69-001 Intercom Adapter jack (10-pin HR10A) to the audio panel jack connector (TJ-120 or equivalent) via adapter cable CAB-WJ2-0004 - 10 Pin Hirose Plug to U174 Plug).

The JB60-001 Headset Adapter jack is a 6-pin female Lemo connector. A headset can be inserted directly into the JA68 (ANR direct), or via a headset adapter (CAB-HSET-0001 helicopter headset to 6pin adapter).

3.1.3 Turn On Adapters and Verify Connection

On the JB60-001 Headset Adapter, turn the VOL knob fully counterclockwise to minimum. Turn on the JB60-001 Headset Adapter and the JB69-001 Intercom Adapter. On both units the PWR ON and LOW BATT annunciators will illuminate for two seconds.

- When a unit is turned on, the PWR ON annunciator will illuminate for 2 seconds, and the unit will start to search for its paired unit.
- While the unit is searching for its paired unit the PWR ON annunciators will triple-flash every 1.5 seconds.
- When the unit is connecting to its paired unit, the PWR ON annunciators will double-flash every 1.5 s until connection is established.
- After connection, the PWR ON annunciator will illuminate steady green until the unit is turned off.

3.1.4 Verify Audio Operation

Set the aircraft audio system's VOX mode to live or key the aircraft audio system's ICS PTT for the headset connection used by the JB69-001 Intercom Adapter.

Adjust the JB60-001 Headset Adapter's VOX control to fully counterclockwise and the VOL control to achieve a comfortable listening level. Confirm that the microphone audio is live - all microphone audio is heard in the phones. Confirm that the audio level increases as the VOL control is rotated clockwise and decreases as the VOL control is rotated counterclockwise.

Adjust the Headset Adapter's VOX control to fully clockwise and confirm that the microphone audio is off.

Press the Headset Adapter's ICS PTT button and confirm that microphone audio is heard in the phones.

Adjust the Headset Adapter's VOX control for a comfortable speaking level and return the aircraft audio system's controls to its previous settings.

3.2 wiJAC™ Adjustments and Pairing



CAUTION: To prevent potential damage or loss of function, the internal adjustments, controls and CONFIG port should **only** be used by qualified technical personnel. Contact your installing agency for any required changes.

3.2.1 Pairing Process

The **wiJAC2-001** Wireless Intercom System consists of one JB69 Intercom Adapter, and one factory-paired JB60 Headset Adapter.

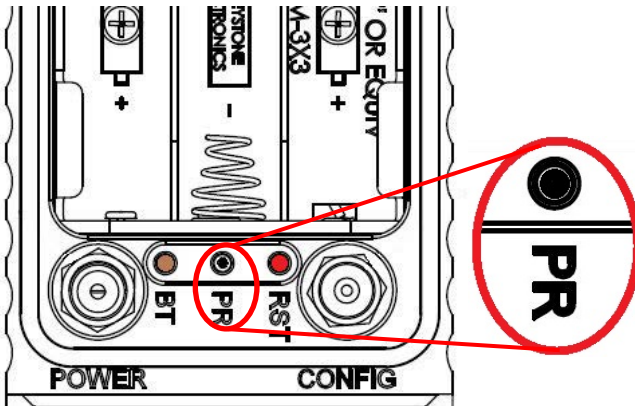

If either the JB60 or JB69 has been replaced, it will be necessary to re-pair the units. This may also be necessary if either of the units has undergone maintenance.

To locate the pair switch, the battery cover must be removed from the unit.

When the battery cover is removed, the pair switch (P) can be seen on the lower edge of the compartment.

The JB60/JB69 pairing process is described in the following steps:

1. **Turn off the JB69 and previously paired JB60.**
2. **Turn on the JB69.**
The JB69 enters the standby mode (Power Annunciator blinks in sets of two or three flashes). If the Power Annunciator stays on continuously, the JB60 is still powered on and connected to the JB69. Turn off the JB60.
3. **On the JB69, press and hold the Pair Switch (4 seconds) until the Power and Low Battery Annunciators start flashing rapidly (10 flashes /second). Release the Pair switch.**
The JB69 enters the pairing mode (Power Annunciator is flashing at a medium rate (5 flashes /second) and can now be paired with the JB60.
4. **Turn on the JB60 to be paired with the JB69.**
The JB60 enters the standby mode (Power Annunciator blinks in sets of two or three flashes).
5. **On the JB60, press and hold the Pair Switch (4 seconds) until the Power and Low Battery Annunciators start flashing rapidly (10 flashes /second). Release the Pair switch.**
The JB60 enters the pairing mode (Power Annunciator is now flashing at a medium rate (5 flashes /second) and will complete the pairing process automatically with the JB69.

The JB60 and JB69 indicate they have completed the pairing process when the Power Annunciators are on continuously.



4 wiJAC™ System Operation

4.1 Overview

When both units are turned on and connected, phones audio from the aircraft audio system is transmitted from the Intercom Adapter, received by the Headset Adapter and output on the headset's phones. Microphone audio from the headset's microphone is transmitted from the Headset Adapter, received by the Intercom Adapter and output to the aircraft's audio system.

4.1.1 Listening Operation

The Headset Adapter's Phones Volume (VOL) controls the level of audio heard in the headset's ear phones. As ambient noise levels change, the volume can be adjusted.

4.1.2 VOX Speaking Operation

To use the JB60-001 Headset Adapter hands-free, adjust the VOX control so that the microphone audio is turned on when speaking in to the headset's microphone at a comfortable level, or at a level to keep the ambient noise from turning on the microphone audio.

4.1.3 ICS PTT Speaking Operation

To use the JB60-001 Headset Adapter in high-noise environments, adjust the VOX control fully counter-clockwise until the knob clicks into detent position. To communicate, press and hold the JB60-001 Headset Adapter's ICS PTT button and speak in to the headset's microphone.

4.1.4 Live Speaking Operation

To use the JB60-001 Headset Adapter so that the microphone audio is always turned on, adjust the VOX control fully counter-clockwise until the knob clicks into the detent position, then slightly clockwise until the knob clicks out of the detent.

4.1.5 Low Battery Warning

When the unit's battery charge is low, the LOW BATT annunciator will triple flash every 1.5 seconds. When the JB60-001 Headset Adapter battery charge is low, a triple-beep will be heard in the headset once every minute.



Note: JAC recommends that the batteries should be charged or replaced immediately when the LOW BATT warning illuminates during use.

When the battery charge level is critical, the unit will turn off. When one unit is off the other unit will begin searching for its paired unit and its PWR ON annunciator will flash.

4.1.6 Operation during Charging

The units will still operate while the Charging Port is connected to a USB power source, but the batteries will charge at a slower rate. Additional noise may be heard on the audio system while the Charging Port is connected to a USB power source.

4.1.7 Loss of Audio

If there is no audio heard in the headset, check the PWR ON annunciator on the JB60-001 Headset Adapter and the JB69-001 Intercom Adapter. If a unit is off, turn it on and verify connection and operation.

If the battery charge is low, replace or recharge the batteries or connect the headset directly to the aircraft audio system.

If audio is unintelligible, turn off and remove the JB60-001 Headset Adapter and the JB69-001 Intercom Adapter and connect the headset directly to the audio panel.



If another aircraft system is experiencing a fault, turn off and remove the JB60-001 Headset Adapter and the JB69-001 Intercom Adapter and connect the headset directly to the audio panel. Do not use the JB60-001 Headset Adapter and the JB69-001 Intercom Adapter if they appear to be the cause of the fault.

4.1.8 Battery Life

The operating duration of the **wiJAC2-001** system with fully charged batteries before battery replacement is required depends on the following factors:

- **Distance between Headset Adapter and Intercom Adapter:**
The closer together the units are the lower the radio frequency (RF) power required for connection. This will increase the battery life.
- **Obstacles between the Headset Adapter and Intercom Adapter (VOL):**
Minimising the aircraft metal structures, human bodies, cargo and other obstacles between the units will reduce the RF power needed for connection and increase the battery life.
- **Charge capacity of the batteries installed:**
The higher the capacity of the batteries, typically specified as 2000 to 2400 mAh (milliamp-hours), the longer the battery life.
- **The type of batteries installed and the operating temperature:**
During low temperature operation, rechargeable batteries will lose capacity. When operating in low temperatures use alkaline batteries for a longer battery life.
- **The phones volume level and usage rate:**
The lower the volume level and the less often audio is output to the phones, the longer the battery life.

5 Compliance Statements

5.1 FCC compliance statement

This device complies with Part 15 of the FCC Rules for only portable part.

Contains transmitter module IC: 9576A-SC14S. Operation is subject to the following two conditions:

- (1) this device may not cause harmful interference, and
- (2) this device must accept any interference received, including interference that may cause undesired operation of the device.

Module transmetteur ID IC: 9576A-SC14S. Son fonctionnement est soumis aux deux conditions suivantes:

- (1) cet appareil ne doit pas causer d'interférences nuisibles et
- (2) l'appareil doit accepter toute interférence reçue y compris les interférences peuvent perturber le fonctionnement.

5.2 Industry Canada compliance statement

This device complies with Industry Canada licence-exempt RSS standard(s). Operation is subject to the following two conditions:

- (1) this device may not cause interference, and
- (2) this device must accept any interference, including interference that may cause undesired operation of the device.

Le présent appareil est conforme aux CNH d'Industrie Canada applicables aux appareils radio exempts de licence. L'exploitation est autorisée aux deux conditions suivantes :

- (1) l'appareil ne doit pas produire de brouillage, et
- (2) l'utilisateur de l'appareil doit accepter tout brouillage radioélectrique subi, même si le brouillage est susceptible d'en compromettre le fonctionnement.